

**INSTRUCTION
MANUAL
FRG-7700**

YAESU MUSEN CO., LTD.

TOKYO JAPAN

TABLE OF CONTENTS

	(Page)
GENERAL DESCRIPTION	(1)
SPECIFICATIONS	(2)
SEMICONDUCTOR COMPLEMENT	(3)
CONTROLS AND SWITCHES	(4)
INSTALLATION	(8)
OPERATION	(13)
BLOCK DIAGRAM	(18)
CIRCUIT DESCRIPTION	(19)
MAINTENANCE AND ALIGNMENT	(22)
PARTS LIST	(25)

ALL MODE COMMUNICATIONS RECEIVER FRG-7700



GENERAL DESCRIPTION

Available as an option for the FRG-7700 is Yaesu's exciting memory feature, which allows the storage and recall of up to twelve discrete frequencies. This allows the operator to watch several stations with pushbutton ease, thus eliminating the considerable effort involved in tuning manually for each of several stations one wants to watch. A memory backup feature is provided for the memory unit to preserve memories when power is removed (three penlight cells required, batteries not supplied).

Available as an option for the FRG-7700 is Yaesu's exciting memory feature, which allows the storage and recall of up to twelve discrete frequencies. This allows the operator to watch several stations with pushbutton ease, thus eliminating the considerable effort involved in tuning manually for each of several stations one wants to watch. A memory backup feature is built into the memory unit (three penlight cells required, batteries not supplied).

The FRG-7700 features high sensitivity, excellent selectivity, digital plus analog display of the operating frequency, and a built-in digital quartz clock that can be programmed to turn the receiver on and off. A snooze timer is included in the clock feature. The timer may also be used to control peripheral equipment such as a tape recorder, for unattended recording of programs you might otherwise miss because you must be away from your station.

Top performance features include a highly effective noise blanker, selectable fast/slow AGC (Automatic Gain Control) circuit, an audio filter which may be adjusted to improve interference rejection, an easy-to-read S-meter, and two RF attenuators (one fixed, one continuously adjustable) for operation under very strong signal conditions. For FM operation, a squelch control will silence the receiver until a signal is received. Convenient interface jacks for tape recorder control, audio output to an external speaker or tape recorder, receiver muting, and for listening via headphones make the FRG-7700 truly the most versatile receiver to be made available to the shortwave listeners of the world.

We recommend that this manual be read carefully prior to operating the FRG-7700. With proper care in installation and operation, this receiver will provide you with many years of trouble-free operation.

SPECIFICATIONS

Frequency Range:

150 kHz – 29.999 MHz (30 bands)

Modes:

AM, SSB (USB, LSB), CW, FM

Sensitivity:

	AM	SSB/CW	FM
0.15MHz–0.3MHz	30 μ V/500 Ω	3 μ V/500 Ω	–
0.3MHz–2MHz	25 μ V/500 Ω	2 μ V/500 Ω	–
2MHz–29.999MHz	5 μ V/50 Ω	0.5 μ V/50 Ω	1 μ V/50 Ω

Selectivity:

AM W (Wide)	12 kHz (–6 dB)	25 kHz (–50 dB)
AM M (Medium)	6 kHz (–6 dB)	15 kHz (–50 dB)
AM N (Narrow)	2.7 kHz (–6 dB)	8 kHz (–50 dB)
SSB/CW	2.7 kHz (–6 dB)	8 kHz (–50 dB)
FM	15 kHz (–6 dB)	30 kHz (–40 dB)

Stability:

Less than ± 1 kHz from 1 to 30 minutes after power ON.

Less than ± 300 Hz after 30 minute warm-up.

Antenna Impedance:

0.15 MHz – 2 MHz BC 500 ohms
(unbalanced)

2 MHz – 29.999 MHz, SW/BC 50 ohms
(unbalanced)

Audio Output:

1.5 Watts (8 ohms, 10% THD)

Speaker Impedance:

8 ohms

4-16 ohms for external speaker or headphone

Power Requirement:

100/120/220/240 volts, AC 50/60 Hz

Power Consumption:

		With Memory Unit
Standby:	AC 10 VA	AC 10 VA
ON:	AC 33 VA	AC 39 VA

Size:

334(W) x 129(H) x 225(D) mm

Weight:

Approx. 6 kg

6.5 kg (with Memory Unit)

SEMICONDUCTOR COMPLEMENT *

ICs: HD10551P 2 MB8718 1 MB84040B 1 MC4044P 1 MC14024BCP 2 MC14046BCP 1 MC14069UBCP 1 MC14504BCP 1 MC14518BCP 2 MC14555BCP 1 MC14556BCP 1 MSM4023RS 1 MSM5524RS 1 μPB553C 1 μPC575C2F 1 μPD5101LC 6 μPC78L05A 1 SN16913P 3 SN74LS123 1 SN74LS192 4 SN74LS196 1 SN74LS290 1	SN74LS293 1 TA7061AP 1 FETs: 2SK107-3 2 2SK125 4 3SK73GR 8 Transistors: 2SA733AQ 17 2SC535A 1 2SC900E 4 2SC945AQ 70 2SC1047C 1 2SC1317R 1 2SC1384R 3 2SC1393L 2 2SC1674L 4 2SC1959Y 1 2SD288K 1 2SD882Q 3 MPS-A13 1	Diodes: 1N60 10 1S188FM 4 1SS53 64 10D1 1 FC52M 2 FC63 1 MV104 5 RD4.7EB2 1 RD5.6EB2 4 RD7.5EB1 1 RD9.1EB2 1 RD10EB1 1 S2V10 1 S2VB10F 1 LEDs: TLG-208 1 TLY-205 2 TLY-208 1 * Including Memory Unit
--	---	---

Specifications subject to change without notice or obligation

ACCESSORIES

The following accessories are packaged along with the FRG-7700:

- (1) AC Power Cable (T9013280) 1 ea.
- (2) Extra fuses 100-120V 1A (Q0000002)
 220-240V 0.5A (Q0000001) 2 ea.
- (3) Wire for antenna (Q3000004) 10 m.
- (4) Extender feet with pads (R3054620) 2 ea.

AVAILABLE OPTIONS

- (1) Memory Unit
- (2) Memory/Clock Backup Batteries (AA Size)

NOTE

In this manual, discussion of the memory feature will omit repetitive use of the word "option," in the interest of brevity. The standard FRG-7700 does not include the memory unit, which is available as an extra-cost option from your Yaesu dealer. The AA size penlight cells required to activate the memory backup feature are not supplied with the memory unit.

CONTROLS AND SWITCHES

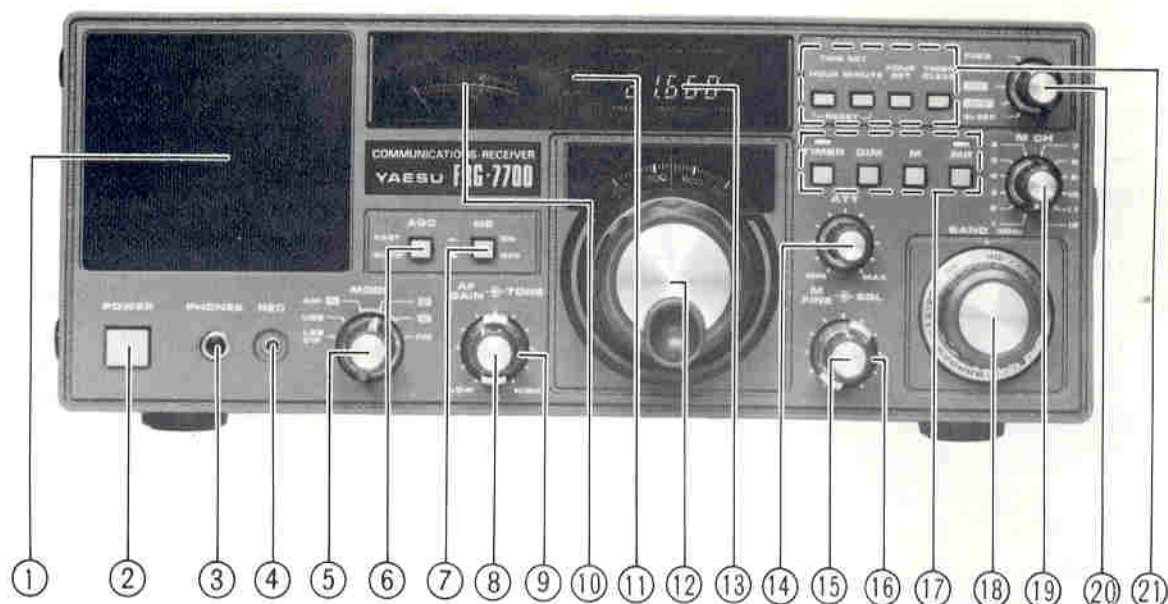

FRONT PANEL

(1) SPEAKER

Internal speaker

(2) POWER

This is the main ON/OFF switch for the receiver. When the POWER switch is in the OFF position, on/off control may be exercised by the clock timer. See the "Operation" section for details.

(3) PHONES

This is a standard 1/4" headphone jack. When the headphone plug is inserted into this jack, the internal speaker is automatically cut off. The audio output impedance is 8 ohms.

(4) REC

This miniature phone jack is for recording purposes. The output level is approximately 100 mV (fixed), irrespective of the setting of the AF GAIN control.

(5) MODE

This control chooses the desired mode:

LSB/CW Use this position for lower sideband (LSB) and Morse Code (CW) reception.

USB Use this position for upper sideband (USB) reception. This position may also be used for CW reception, if desired.

AM N Use this position for narrow-band AM reception. Under conditions of extremely heavy adjacent frequency interference, this position of the mode switch may allow AM reception where a wider mode would be unusable. There will be some degradation in fidelity in the AM N position, however.

AM M For all-around AM reception, the AM M position of the mode switch may be used. Because of the wider bandwidth, the fidelity on the incoming signal is much better than with the AM N filter.

AM W Under clear band conditions, the AM W provides the widest bandwidth and best fidelity.

FM This position selects reception of FM signals.

(6) AGC

This switch allows selection of the optimum AGC (Automatic Gain Control) decay time. The SLOW position is normally used for AM reception, while the FAST position is normally chosen for Morse Code (CW) reception. For SSB reception, the optimum position is determined by band conditions and the adjacent-frequency interference level.

(7) NB

This switch, when pressed, activates the noise blanker for reduction in the level of interfering pulse-type noise.

(8) AF GAIN

The AF GAIN control varies the volume level from the speaker. Clockwise rotation increases the volume level.

(9) TONE

This control varies the high-frequency audio response. The variation in audio fidelity provided by the TONE control is highly useful in minimizing interference from heterodynes and other high-pitched noises that might ruin reception.

(10) S-METER

The S-meter provides a relative indication of the signal strength on the incoming signal. The upper scale is calibrated in S-units from S1 to S9, with stronger signals indicated in dB over S9. The lower scale is calibrated in S-units compatible with the SINPO code, as shown in Table 1.

(11) AM, PM

These are AM and PM indicators for the clock.

(12) MAIN DIAL

The main dial determines the operating frequency of the FRG-7700, in conjunction with the setting of the BAND switch.

(13) DIGITAL DISPLAY

The digital display indicates the operating frequency as well as the time. Selection of display of the frequency or time is made via the FUNCTION switch.

(14) ATT

The ATT (Attenuator) control, when rotated in a clockwise direction, reduces the gain of the receiver preamplifier, thus minimizing overloading of the receiver during conditions of extremely strong adjacent-frequency interference. Maximum receiver sensitivity occurs when the ATT control is rotated to the fully counterclockwise position.

(15) M FINE

This control allows fine tuning during memory operation. A frequency excursion of up to 1 kHz may be achieved using this control.

(16) SQL

The SQL (Squelch) control will silence the receiver until a signal is received. The SQL control is usable

ONLY in the FM mode.

(17) CONTROL SWITCHES (TIMER, DIM, M, MR)

TIMER Once the desired on/off timers are programmed into the clock, push this switch to activate the power control timer. In this mode, the digital clock timer will turn the receiver on and off.

DIM This button, when pushed, will allow dimming of the meter lamp, the dial lamps, and the display intensity.

M Push this button to store a frequency into memory.

MR This button, when pushed, transfers frequency control from the main dial to the memory system. Push the button again to return to main dial tuning.

(18) BAND

This switch selects the desired 1 MHz segment within the HF spectrum, with calibrations from 0 MHz to 29 MHz. Also provided are preset marks for the HF amateur radio (ham) bands.

(19) M CH

This switch selects the desired memory channel.

(20) FUNCTION

This switch selects the Digital Display functions.

FREQ All digits of the operating frequency are displayed with resolution to 1 kHz.

CLOCK Time is displayed in a 12-hour format.

ON The ON time, at which the receiver will be turned on, is displayed.

OFF The OFF time, at which the receiver will be turned off, is displayed.

SLEEP The remaining time of the sleep timer is displayed.

(Up to 59 minutes can be set for the sleep timer.)

(21) CLOCK SETTING SWITCHES

HOUR This switch is used for setting hours on the clock and timer. Pressing this switch once will advance the reading by one hour. If this switch is held for more than two seconds, the hour reading will advance continuously.

MINUTE This switch is used for setting minutes. The setting procedure is identical to that for setting hours.

HOUR SET

This switch, when pressed, resets the minute and second digits of the clock to zero. For example, if more than 30 minutes are displayed on the clock, pressing the HOUR SET button will advance the clock to the next hour. If less than 30 minutes have elapsed in the hour, pressing the HOUR SET button will zero the minutes and seconds, but leave the hour reading unchanged. This feature facilitates easy time setting.

TIMER CLEAR

This switch, when pressed, clears the remaining time before the programmed off time. After the timer turns the receiver on in the TIMER mode, you may push the TIMER CLEAR button to turn the receiver off. The following day, the receiver will turn ON again at the programmed time. In the sleep timer mode, pushing this switch will cause the remaining time to be zero, and the receiver will turn off.

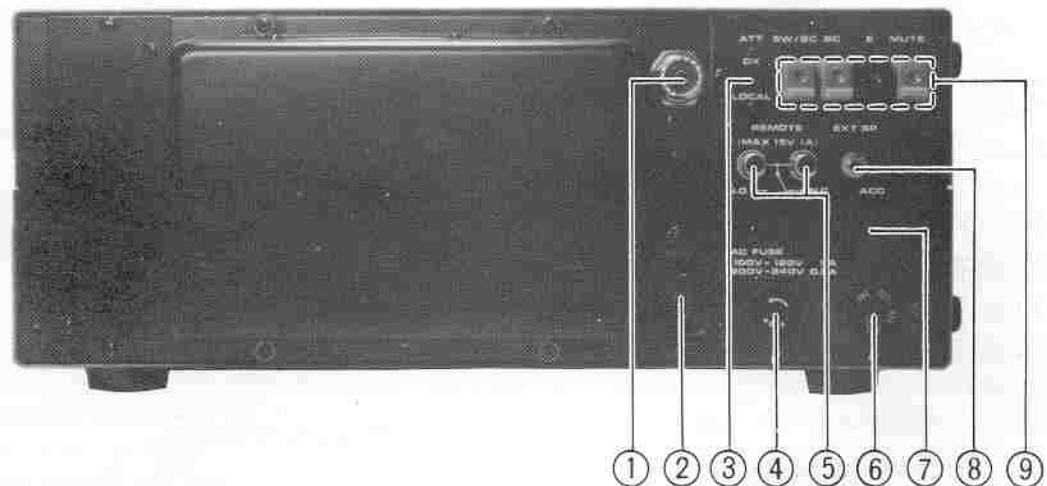

REAR PANEL

(1) COAX ANT

This is a standard UHF type coaxial connector for shortwave and standard broadcast listening. This connector is wired in parallel with the SW/BC terminals.

(2) AC

The AC power cable should be connected at this point.

(3) ATT

The ATT (Attenuator) switch activates an attenuator in the incoming signal path when the LOCAL position is selected. For best receiver sensitivity, this switch should be placed in the DX position.

(4) AC LINE FUSE

For 100/120 volt operation, a 1 amp fuse should be installed here. For 200/240 volt operation, a 1/2 amp fuse should be installed here. When replacing fuses, be absolutely certain to use a fuse of the proper rating, as our warranty does not cover damage caused by use of an improper fuse.

(5) REMOTE (N.O./N.C.)

These RCA type jacks may be used for control of peripheral equipment such as tape recorders, etc. When the TIMER switch is activated, and the ON time is reached, the internal switching relay is activated. When the OFF time is reached, the relay returns to its normal condition. The normally open and normally closed jacks on the rear panel may then be used, according to the control requirements of your station equipment. See the "Operation" section for details.

(6) AC VOLTAGE SELECTOR

This is for selection of the proper input AC voltage. Set this selector for your local line voltage. If you have any question about your local line voltage, consult your local Yaesu dealer before attempting operation of this equipment.

(7) ACC

This is a 5 pin DIN accessory jack which affords access to AGC voltage, an 11 volt DC line, and the mute line.

(8) EXT SP

An external speaker may be connected via this jack. The audio output impedance is 4-16 ohms. Insertion of a plug into this jack automatically cuts off the internal speaker.

(9) SW/BC, BC, E, MUTE

SW/BC is for connection to a long wire antenna for both shortwave and broadcast listening.

BC is for connection to a long wire antenna for broadcast band listening.

E is a ground connection.

MUTE provides a means of muting the FRG-7700 (an external standby switch). Shorting the MUTE terminal to ground will mute the receiver.

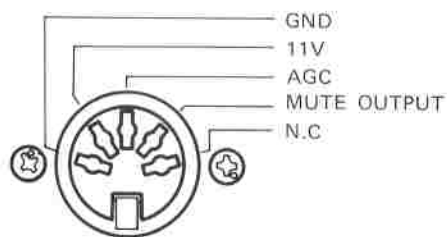
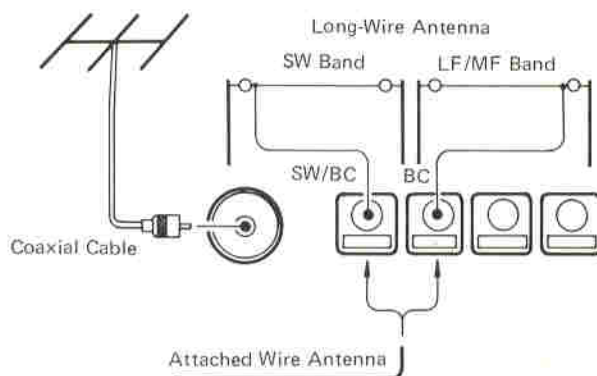

ACC CONNECTIONS

SINPO CODE

	Signal Strength	Degrading Effect of			Overall Rating
		Interference	Noise	Propagation Disturbance	
	S	I	N	P	O
5	Excellent * (60dB)	Nil ● (-40dB)	Nil (-40dB)	Nil ○ (0dB)	Excellent
4	Good (45dB)	Slight (-30dB)	Slight (-30dB)	Slight (10dB)	Good
3	Fair (30dB)	Moderate (-20dB)	Moderate (-20dB)	Moderate (20dB)	Fair
2	Poor (15dB)	Severe (-10dB)	Severe (-10dB)	Severe (30dB)	Poor
1	Barely Audible (0dB)	Extreme (0dB)	Extreme (0dB)	Extreme (40dB)	Unusable

Table 1

* RECEIVER INPUT LEVEL
● RATIO TO SIGNAL
○ DEPTH OF FADING, ECHO, ETC.

INSTALLATION

Best performance from this equipment can only be obtained if proper care is observed during installation. While the setup procedure for the FRG-7700 is extremely straightforward, permanent damage to the set can occur if improper voltage is applied to the unit or if external connections are improperly made. Before attempting operation of your FRG-7700, be certain to read the following sections carefully.

UNPACKING AND INITIAL INSPECTION

Carefully remove the FRG-7700 from its carton, and inspect it for any signs of physical damage. Rotate the knobs and push the switches, checking each for normal freedom of action. Should any damage be observed, document it carefully, and notify the shipping company immediately. Save the carton and foam packing material for possible use at a later date.

AC VOLTAGE SELECTION

Your FRG-7700 is supplied with a power transformer capable of operation from 100, 120, 220, or 240 volts, as these voltages are the ones most commonly used throughout the world. Your Yaesu dealer has taken care to make sure that your radio is set up for the voltage used in your area. However, in some parts of the world, more than one voltage is available for use. It is extremely important that the FRG-7700 not be subjected to an improper supply voltage.

Therefore, before connecting the power cord to the radio, make absolutely certain that the voltage specification marked on the rear panel of your receiver (lower right-hand corner) matches your local supply voltage. At the same time, check to make certain that a fuse of the proper rating is installed. For 100/120 volt operation, use a 1 amp fuse. For 220/240 volt operation, use a 1/2 amp fuse. The fuse holder is located on the rear panel. NEVER remove the fuse holder when the power cord is plugged into the wall outlet.

CAUTION

Be certain to observe the above precautions regarding power connections and fuses. Our warranty does not cover damage caused by improper supply voltage nor damage caused by use of an improper fuse.

To set the radio up for operation on a different voltage (as, for example, should you move from Europe to the United States), proceed as follows:

- (1) Disconnect the power cord from the rear of the FRG-7700.
- (2) Remove the label covering the voltage selector control on the rear panel of the receiver.
- (3) Insert a screwdriver into the slot on the voltage selector. Rotate the selector until the proper voltage is at the very bottom of the selector, in line with the pointer.
- (4) If a change is made from 100/120 volts to 220/240 volts, or vice versa, be certain that you install a fuse of the proper rating. For 100/120 volts, use a 1 amp fuse, and for 220/240 volts, use a 1/2 amp fuse.
- (5) Make a small label to indicate the new voltage specification for the receiver, and secure it over the voltage selector.
- (6) Connect the power cord to the rear panel "AC" jack, and plug the power plug into your wall outlet.
- (7) If you have any doubt about your local supply voltage, ask your Yaesu dealer. Improper supply voltage must not be applied to this instrument.

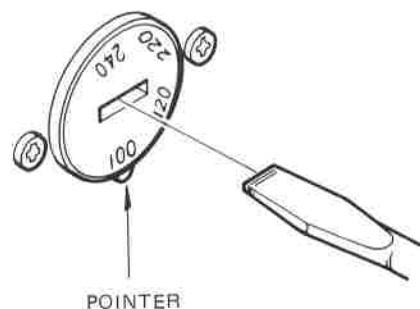

AC VOLTAGE SELECTOR

BACKUP BATTERY INSTALLATION

Memory-equipped FRG-7700 receivers include a backup feature which will hold the memory even when the unit is unplugged from the supply voltage. The backup feature requires three AA size penlight cells (not supplied), which should be installed as shown in Figure 1. Be absolutely certain to observe the proper polarity of the batteries during installation.

Battery consumption is extremely low, but we recommend that the backup batteries be replaced once per year. If you have not used the FRG-7700 for a long time, we recommend that you inspect the penlight cells to ensure that no leakage from the batteries has occurred. Damage caused by battery leakage or improper battery polarity is not covered by our warranty.

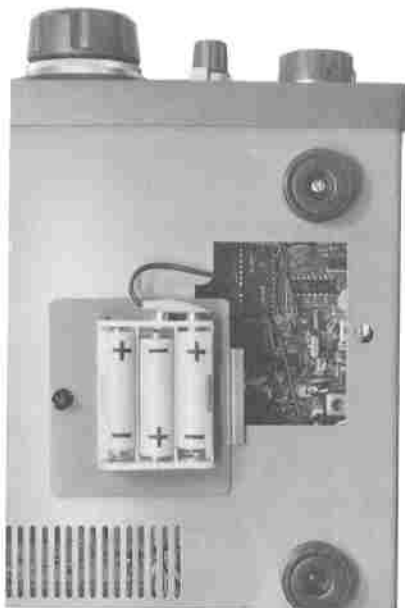

Figure 1

GROUND CONNECTION

For best performance and safety, the FRG-7700 should be connected to a good earth ground. The ground lead should be a heavy-gauge braided cable or wire, and should be connected to the terminal marked "E" on the rear panel of the receiver.

ANTENNA INSTALLATION

The antenna is an important part of your station installation. Without a good antenna system, it will be difficult for you to take full advantage of your FRG-7700 receiver's many high-performance features. For best reception, please follow the guidelines presented below regarding antenna installation.

(1) Low Frequency (LF) and Medium Frequency (MF) Reception (Below 2 MHz Exclusively)

Good all-around reception will occur if a single long wire is connected to the BC terminal on the rear of the receiver. Insulate the wire at the far end, and at the point where it enters your house; ceramic insulators suitable for antenna installations are available from your Yaesu dealer. The wire itself may be either bare or insulated (plastic or vinyl covering on the wire), with the constraint that bare wire should not come in contact with trees or other obstructions.

In general, the antenna wire should be as long, high, and in the clear as possible. If these simple recommendations are followed, good reception will be easy to obtain.

(2) Shortwave (SW) Reception (Above 2 MHz Exclusively)

Maximum performance is secured in the shortwave bands through the use of a resonant antenna having an impedance of 50 ohms at the design frequency. A center-fed "dipole" antenna cut for the most-listened-to frequency will easily satisfy this requirement. Dipole antennas should be fed with coaxial cable, and suitable antenna kits are available from your Yaesu dealer.

However, the shortwave bands are quite wide, and no dipole antenna will be resonant throughout this entire frequency range. The best course of action, then, is to cut the legs of the dipole antenna to the longest (equal) lengths that your installation area will allow. This will provide an excellent listening system for your shortwave station.

Should you wish to cut your dipole antenna for optimum performance on a particular shortwave band, the formulas of interest are:

$$\text{Length (feet)} = 468/\text{frequency (MHz)}$$

$$\text{Length (meters)} = 142.5/\text{frequency (MHz)}$$

Notes Regarding Antenna Installations

For general reception (listening on both the LF/MF and shortwave bands), the antenna connection should be made to the SW/BC connector or to the coaxial antenna connector on the rear panel. If your primary interest is only on the LF/MF bands, then connect your antenna wire to the BC terminal. Do not connect one antenna to the SW/BC terminal (or coax connector) and another antenna to the BC connector at the same time; if you do, overloading or intermodulation distortion may be created, degrading receiver performance.

Use extreme caution when installing your antenna system. Every year, several people are electrocuted because their antenna touched a high-voltage wire providing their normal house current. It is extremely important that your shortwave antenna be located such that it cannot possibly come in contact with electric wires even in a disastrous windstorm.

REMOTE TERMINAL CONNECTIONS

The REMOTE terminals are connected to a relay, which is an electronically controlled switch. In the case of the FRG-7700, the switching relay is controlled by the clock timer, allowing you to control the operation of a tape recorder or other equipment simply by the proper setting of your FRG-7700 clock controls. The "N.O." terminal is "normally open," which means that the relay will cause no connection to be made from the center pin to ground until the timer activates the relay. The "N.C." terminal is "normally closed," which













means that the relay contacts will cause a connection to be made between center pin and ground until the relay is activated; the relay will then open the connection.

Most tape recorders have a "footswitch" connection which allows external control. In some cases, this external on/off control line is incorporated into the microphone cord. Closing an external switch then allows the tape recorder to be turned on. To use this kind of tape recorder with the FRG-7700, connect a shielded cable from the tape recorder footswitch jack to the FRG-7700 "N.O." jack, and connect a shielded cable from the FRG-7700 "REC" jack on the front panel to the tape recorder "LINE IN" or "MIC" jack, depending on the levels accepted by your tape recorder. Remember that the REC jack on the FRG-7700 is not controlled by the AF GAIN control, but the EXT SP jack is; you may want to connect your audio input line differently for your particular requirements.

Details of the operation of the timer are included in the "Operation" section of this manual. Table 2 indicates the position of the relay contacts tied to the REMOTE terminal.

MUTE CONNECTION

When the FRG-7700 is used in conjunction with a transmitter, the MUTE terminal on the rear panel may be used to silence the receiver when transmitting. Do not forget to use a relay for external antenna switching between the receiver and transmitter. Shorting the MUTE terminal to ground will cause the receiver to be silenced.

TIMER FUNCTION	N.O. Terminal		N.C. Terminal		FRG-7700 (with POWER SW OFF)
ON TIMER	 OPEN	→  CLOSED	 CLOSED	→  OPEN	ON at the programmed time
OFF TIMER	 CLOSED	→  OPEN	 OPEN	→  CLOSED	OFF at the programmed time
SLEEP TIMER	 OPEN	→  CLOSED	 CLOSED	→  OPEN	OFF after the programmed period of time

→ When the timer is activated

Table 2

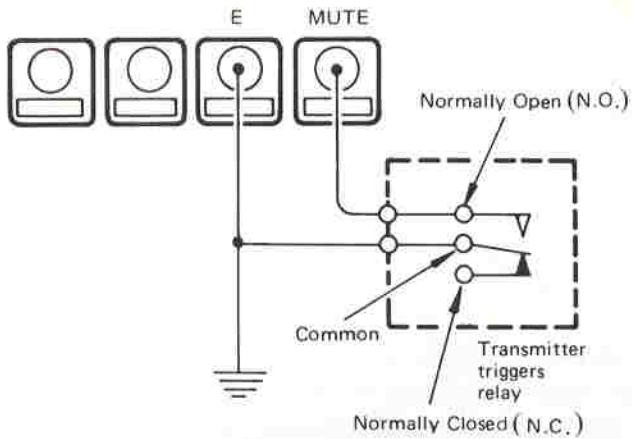

PHYSICAL LOCATION OF THE FRG-7700

The FRG-7700 will perform well in any location that allows free passage of air around the cabinet. Solid state equipment such as the FRG-7700 should not, however, be used in extremely hot environments unless some provision is made (external fan, etc.) for keeping the station temperature less than 40°C.

INTERCONNECTION WITH YR-901 MORSE CODE/TELETYPE READER

The YR-901 is a high-performance computerized translator which will allow display on a video monitor of incoming Morse Code and/or teletype (RTTY) signals. The YR-901 and YVM-1 Video Monitor are options available from your Yaesu dealer.

Complete operation instructions are included with the YR-901. Please refer to the drawing below for details of the extremely simple interconnections required. Please note that the SP-901 speaker is not mandatory for use with the YR-901, as the latter includes a built-in speaker.

The YR-901 will allow you to see for yourself late-breaking teletype news as it comes from abroad on circuits used by the international news services. Amateur radio Morse Code and teletype communications, and a host of other exotic transmissions will unfold before you on the video screen. See your Yaesu dealer for details.

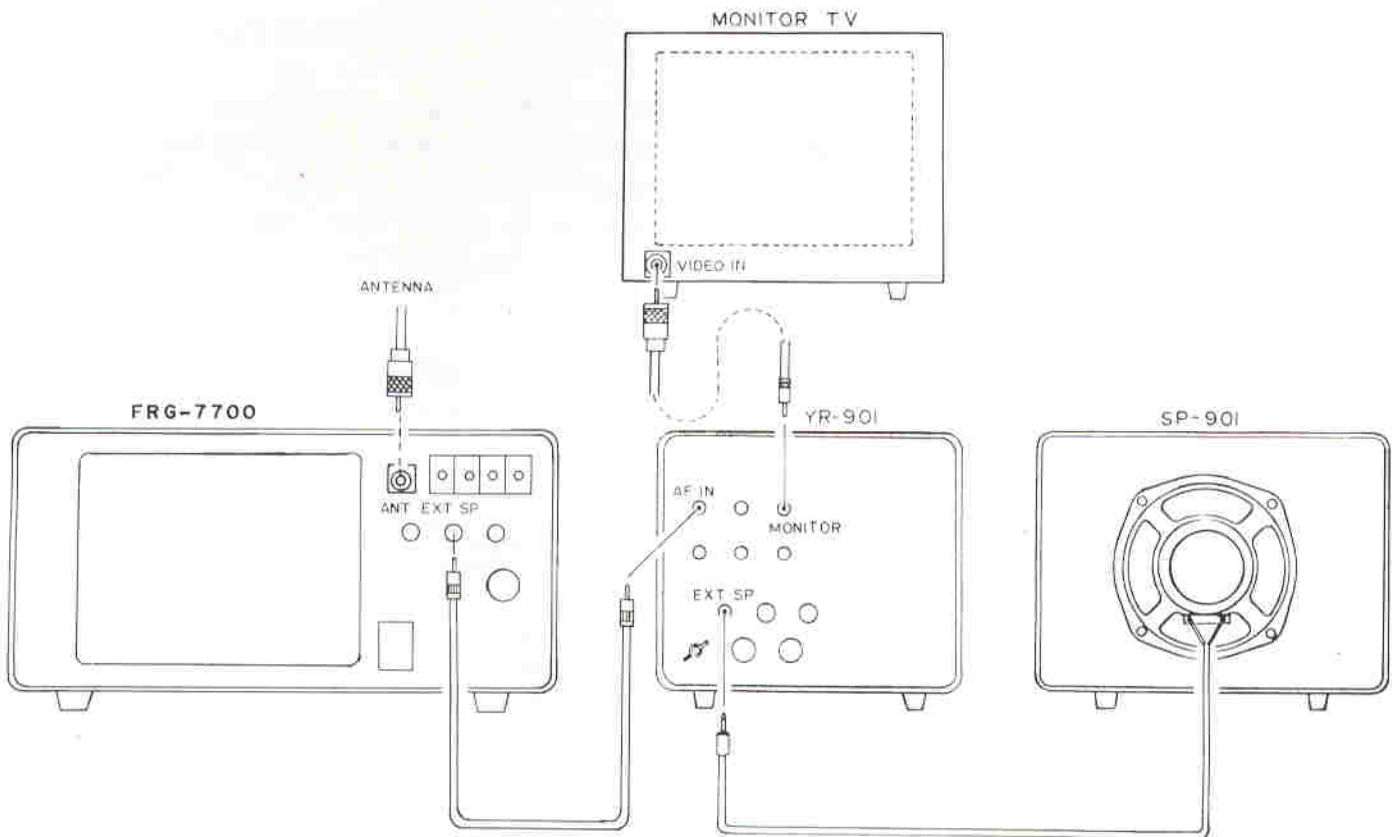

FRG-7700/YR-901/YVM-1/SP-901

MEMORY UNIT INSTALLATION

The optional Memory Unit is easily installed in a matter of minutes. Please follow the below instructions carefully, in order to make the proper connections.

- (1) Remove the small cover from the rear panel of the receiver, as shown in Fig. 2.
- (2) Connect the six plugs which are fastened to the cover to the appropriate jacks on the Memory Unit, as shown in Fig. 3.
- (3) Mount the Memory Unit with the supplied self-tapping screws (4 pcs), as shown in Fig. 4, being sure that no wires from inside the unit are protruding.

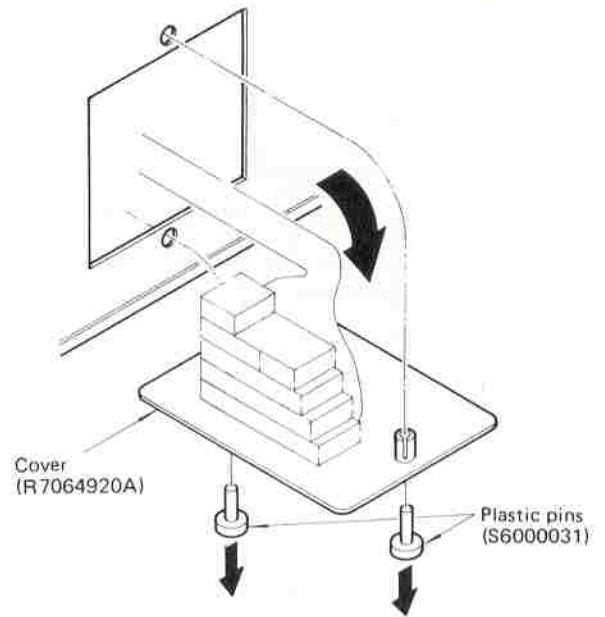

Figure 2

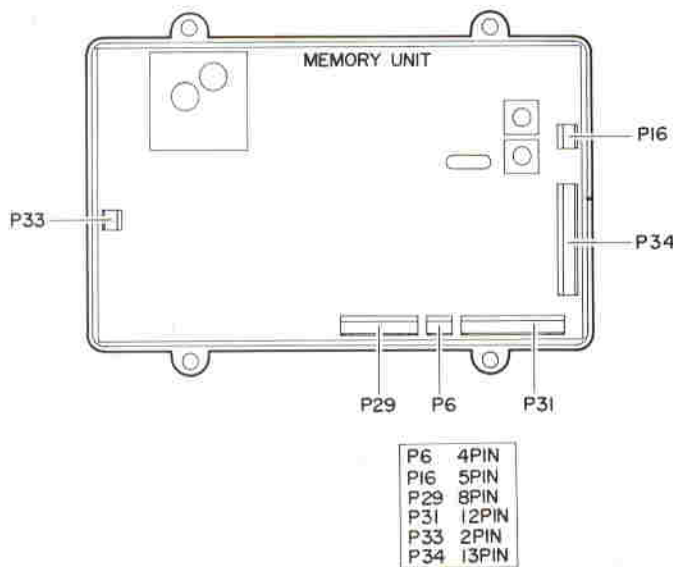

Figure 3

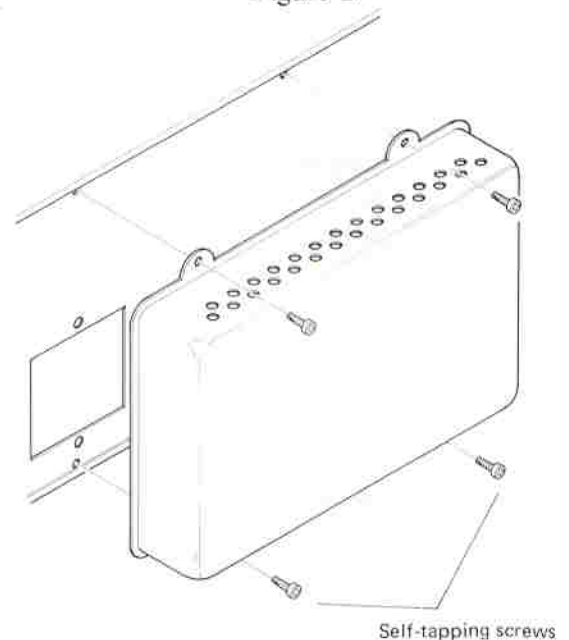

Figure 4

BOTTOM PANEL FEET

The feet on the bottom of the receiver may be changed, should you desire to change the viewing angle for the FRG-7700. The extender feet, packed in the accessory kit for the receiver, may be installed at the front or back, depending on the viewing angle desired. When repacking the receiver for shipping, be certain to replace the original feet. Refer to Figure 5 for mounting details for the bottom panel feet.

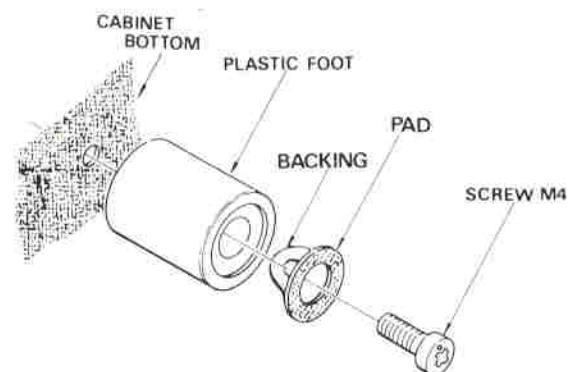

Figure 5

OPERATION

Operation of the FRG-7700 is extremely straightforward. However, the owner should read these pages carefully so as to derive maximum performance from this equipment. Before attempting operation, make certain that all power, antenna, and ground connections have been made correctly.

FREQUENCY SELECTION

The operating frequency is read directly from the digital display. All digits of the operating frequency are displayed, with resolution to 1 kHz. The BAND switch is calibrated in 1 MHz steps, from 0 MHz through 29 MHz, with an additional 10 steps being provided for instant presetting to the bands containing the amateur radio (ham) bands.

To select a frequency, first set the BAND switch to the desired 1 MHz segment, then rotate the main dial to select the last three digits of the frequency. A coarse frequency determination may also be made through the main dial window, which is calibrated every 10 kHz.

AM BROADCAST RECEPTION

- (1) Most commercial broadcast stations in the MF and HF bands use the AM (Amplitude Modulation) mode of operation. To begin, turn the power switch on, and set the mode switch to AM M (AM mode, medium bandwidth).
- (2) Tune in an AM station to the point where the S-meter reading reaches a maximum.
- (3) If there is very heavy interference, you may wish to set the mode switch to the AM N (AM mode, narrow bandwidth) position. This will provide maximum rejection of adjacent-frequency interference, although the narrower bandwidth will cause some loss of fidelity. Conversely, if there is very little interference, you may switch to the AM W (AM mode, wide bandwidth) position. This will provide maximum fidelity.
- (4) The TONE control on the front panel may be used to vary the audio response characteristics

of the receiver. For example, if you are troubled by a high-pitched "heterodyne" signal, rotate the TONE control in a counter-clockwise direction to reduce this interference.

- (5) When extremely strong signals are encountered, the operator may want to reduce the level of these signals. Rotate the ATT (Attenuator) control on the front panel clockwise to reduce the strength of the incoming signals. Should you desire to activate the fixed 20 dB attenuator, set the rear panel ATT switch to LOCAL. For most listening, though, leave this switch set to the DX position.
- (6) For reduction in impulse-type noise (automobile ignition, etc.), push the NB (Noise Blanker) switch. This circuit is highly effective in minimizing this type of interference.
- (7) An Automatic Gain Control (AGC) circuit is included in your FRG-7700. This feature keeps signal strengths adjusted to a constant level under conditions of fading. When rapid fading conditions are encountered, you may want to set the AGC switch to FAST, as the use of the SLOW position might cause a weak signal to be obliterated by an adjacent-frequency station which is much stronger. With some experience, the operator will soon learn the proper settings of the MODE and AGC switches for operation under a variety of conditions.

AMATEUR RADIO (HAM) BAND RECEPTION

Amateur radio operators use a variety of operating modes on the HF bands. However, your FRG-7700 is well equipped to receive the various types of ham signals encountered in day-to-day operation.

SSB Voice Signals

- (1) Amateur radio operators use lower sideband (LSB) on the bands below 10 MHz, and upper sideband (USB) above 10 MHz. Set the mode switch accordingly.

- (2) Turn the power switch on. The meter lamp and digital display will become illuminated.
- (3) Rotate the ATT control fully counterclockwise, and adjust the AF GAIN control for a comfortable listening level.
- (4) Now rotate the main tuning dial until a voice signal is found. Careful adjustment of the main tuning dial will result in excellent clarity on the incoming SSB signal. Under conditions of rapid fading, set the AGC switch to FAST.
- (5) When pulse-type ignition noise is encountered, push the NB switch.
- (6) Adjacent frequency interference may be reduced substantially by counterclockwise rotation of the TONE knob. Also, advancing the ATT knob in a clockwise direction may result in some reduction of interference from a strong adjacent station; such a station may be so strong that the AGC control may cause the receiver to be "pumped," and reduction of the receiver front end gain will reduce this effect.
- (7) Note that the bandswitch contains nine bands which correspond to the amateur radio allocations. This allows simplified band changing when listening to amateurs. The 10, 18, and 24 MHz bands, newly assigned to the amateur service, are not yet approved for amateur operation in most countries, and no amateur operations will be heard until action is taken by the governments involved.

Morse Code (CW) Reception

Morse Code transmissions may be received by placing the mode switch in either the USB or LSB/CW position. The operator may find that adjacent-frequency interference conditions are better in one or the other of the above modes, and that position should be used until conditions change. The main tuning dial should be rotated until a comfortable listening pitch is obtained.

Frequency Modulation (FM) Reception

Frequency modulation operation is becoming more popular on the 29 MHz amateur band. Also, the operator may wish to use the FRG-7700 with a VHF/UHF converter, for listening to FM repeater operation on the VHF and/or UHF bands. Set the mode switch to FM, and rotate the main tuning dial until the best fidelity on the incoming signal is obtained.

For FM operation, the front panel squelch (SQL) control should be advanced to the point where the receiver is just silenced when no signal (only noise) is being received. This will allow silent monitoring during long periods when no stations are active.

MEMORY OPERATION

The memory feature provides a means of storing frequencies you may want to recall at a later time. Up to twelve stations may be stored in memory. Here is the simple procedure for memory storage and recall:

- (1) Set the M FINE control to the 12 o'clock position. Rotate the M CH switch to memory channel 1.
- (2) Tune the receiver to the desired station, being careful to tune for best clarity and fidelity. Press the M (Memory) button. The station is now stored. Continue tuning for additional stations, if desired, and store them in the other memory channels.
- (3) To recall a station previously stored, rotate the M CH switch to the appropriate channel, and press the MR (Memory Recall) button.
- (4) To return control to the main tuning dial, simply push the MR button again. The MR lamp will turn off, and normal tuning will again be possible. The stations stored in memory will not be lost if you release the MR switch; just press it again to return to the memory.

- (5) Note that stations on different bands may be stored in memory. Once stored, they may be recalled without the need to rotate the band switch to the appropriate band. In other words, you may store stations in the 11 MHz, 15 MHz, and 21 MHz bands as you tune them in using the band switch and main tuning dial; once you press the MR button, you only need to rotate the M CH switch to recall these stations, with no change in the position of the bandswitch required.
- (6) The M FINE control may be used to provide fine tuning of ± 1 kHz from a memorized frequency. This may be necessary should the memorized station begin to drift, or should propagation conditions cause new interference to appear on frequency. Judicious use of the AM N position of the mode switch, along with the M FINE control, will provide solid copy on many stations that might otherwise be obliterated by interference.

DIGITAL CLOCK OPERATION

The built-in digital quartz clock is a highly accurate timepiece which adds convenience and flexibility to your FRG-7700 station. The clock will operate so long as the receiver is plugged in, and it will also operate off of the memory backup batteries. When the receiver is initially plugged in, the clock will indicate AM 1:00 and will begin counting. Setting the time is a simple procedure, as shown below.

Example: set the clock to 5:25:00 PM

- (1) Place the FUNCTION switch in the CLOCK position, then push and hold the HOUR SET button. The minutes and seconds will reset to zero. Tune in WWV at 10 MHz (or another international time standard) on the receiver. When the time standard ticks off the start of a new minute, release the HOUR SET button. This will align the count of the seconds to the international time standard.
- (2) Push the HOUR button to advance the hour digit to 5:00. If the HOUR button is held for more than two seconds, the hour digits will advance rapidly until the HOUR button is released.

- (3) Push the MINUTE button to advance the minute digit to 25. When the MINUTE button is pressed and held, the digits will advance rapidly, in the same manner as the hour digit.
- (4) The clock should be accurate within 15 seconds per month. When setting the clock, be certain that the appropriate AM/PM digit is illuminated.

TIMER OPERATION

Four timer functions are available. They are:

ON Timer

In this mode, the receiver is turned on at a pre-programmed time.

OFF Timer

In this mode, the receiver is turned off at a pre-programmed time.

ON/OFF Timer

In this mode, both the on and off times are preset for power control of the receiver.

SLEEP Timer

In this mode, you may set a listening time of up to 59 minutes, after which the receiver will turn off.

To set the timer for on/off automatic control of the FRG-7700, proceed as follows (example—on time 10:30 AM, off time 11:30 AM)

- (1) Set the POWER switch to OFF, and set the function switch to the ON position.
- (2) Set the display to 10:30 AM by pushing the HOUR and MINUTE buttons, in the same way as you did when you preset the clock earlier.
- (3) Set the function switch to OFF. Set the display to 11:30 AM by pushing the HOUR and MINUTE buttons.
- (4) Push the TIMER switch to activate the timer. The FRG-7700 will turn on at 10:30 AM, and turn off at 11:30 AM. Be certain to observe the AM or PM lamps when programming the on and off times.

- (5) If you want to turn the receiver off before the programmed off time, push the **TIMER CLEAR** button.

To set the sleep timer, proceed as follows:

- (1) Turn the **POWER** switch **OFF**, and set the function switch to the **SLEEP** position.
- (2) Push the **MINUTE** switch once. This will cause the sleep time to count back from the 59 minute mark by one minute. Holding the **MINUTE** button down will cause the time to change rapidly, in the same manner as described earlier. If you set the display to 40, the receiver will stay on for 40 minutes, then shut off.
- (3) If you want to turn the receiver off before the programmed off time, push the **TIMER CLEAR** button.

NOTES REGARDING PROPAGATION OF SHORTWAVE SIGNALS

While a complete discussion of the physics of shortwave radio signal propagation is well beyond the scope of this manual, some guidelines are presented below to help you to choose the optimum listening frequency for the time of day and the time of year in which you are operating. This discussion will also help you when you are reading the schedules of overseas broadcast stations; you will soon be able to know instantly why you cannot expect to hear Tokyo on 3.9 MHz at 1:00 in the afternoon.

Shortwave signals are transmitted by huge stations running many thousands of watts of power. Their antenna systems are elaborate and expensive. But all of this equipment would be useless were it not for a property of the ionosphere (a layer of the atmosphere high above the earth) which causes signals to be reflected back to earth when they strike the ionosphere.

Depending on several factors, including the time of day, the time of year, and the current state of solar activity (determined primarily by "sunspots"), the optimum frequency for reflection over a particular distance will change. Another aspect that can be noted is that, for a particular frequency on which you are operating, the distance over which signals will be propagated will change. Thus, in order to hear stations 12,000 km away over a long period of time on a particular day, you will likely have to change your operating frequency (consistent with the broadcast station schedules!) in order to take advantage of changing propagation conditions.

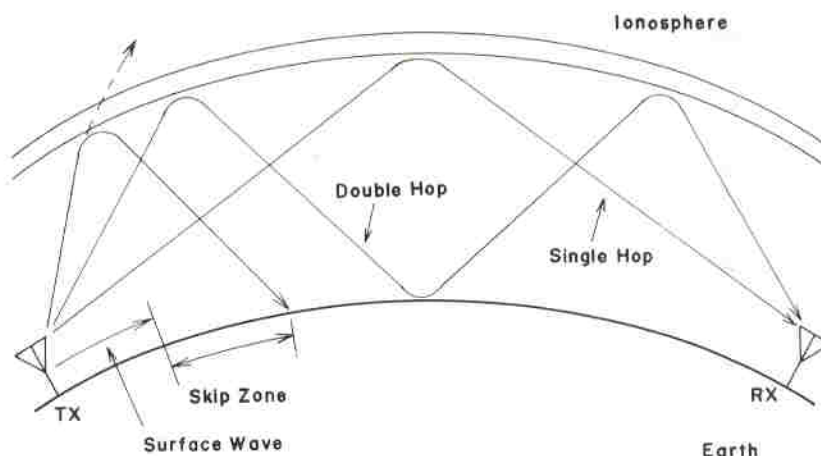

As a general rule, daytime propagation conditions will be best on frequencies from about 12-14 MHz and higher. Propagation at night will generally be best on the 2-15 MHz bands. These general rules often have exceptions, of course; during periods of high solar activity, the 21 MHz band may, for example, be excellent for long-distance propagation well into the night. However, it would be highly unusual for the bands below about 8 MHz to support transoceanic propagation throughout the daytime period.

When reading broadcast station schedules, one must consider not only the time of day at one's own location, but also the time of day at the transmitter location. Let us examine the example of two broadcast stations, one in Tokyo and one in Moscow, both operating on 6 MHz at 6:00 PM local time (for our example, let us say that you live in New York City, USA). Because there are nighttime conditions across most, if not all, of the North Atlantic path that a signal would follow on its way from Moscow to New York, one would normally have a good chance of receiving the broadcast from Moscow. However, the path from Tokyo to New York is largely a daylight path, and our rule of thumb discussed earlier would tell us that it would be difficult, if not impossible, to hear Tokyo at that time on that frequency.

However, if one reads further down the schedule for Tokyo, a broadcast on 15 MHz at the same time may be found. The 15 MHz region (± 5 MHz) is a middle ground which often supports round-the-clock propagation. You would have a much better chance of hearing Tokyo on 15 MHz, because the path is largely over daylight.

Broadcast station managers are well aware of this phenomenon, and this is the reason why their schedules indicate "North American Service" or "Programming Beamed at Southeast Asia." They take propagation conditions into consideration, and aim their antennas carefully, so as to have the best chance of reaching their target area at a time when people will be at home to listen.

The time of year is important for several reasons. For example, at 4:00 PM in New York in June, the sun is still high in the sky. But at 4:00 PM in December, twilight is fast approaching, and nighttime conditions are taking over on the North Atlantic path. Broadcast station managers adjust their schedules so as to use the lower frequencies (below 10 MHz) more heavily in the winter months, because of the increased distance covered by darkness during the winter.

Signals do not always follow the shortest distance from point A to point B (called the "Great Circle" path). They sometimes follow a bent path, or one exactly the opposite of the great circle. This is why it is sometimes possible to hear Tokyo from New York on 7 MHz late in the afternoon in the winter, even though the Great Circle path is in daylight; the signals are traveling along a darkness path around the world. The fact that many stations are louder, and that the transmitting antenna may not be beamed on the optimum path at that time, makes reception extremely difficult. But this is the excitement of shortwave listening—hearing the unexpected. Under tough conditions such as this, the AM-N (narrow bandwidth) position of the mode switch will prove itself to be a highly useful feature.

To conclude our discussion on propagation conditions, we would stress the following general rules. First, use the higher frequencies (15 MHz and up) as your main daylight bands. Secondly, use the low frequencies (below 15 MHz) as your prime nighttime bands. Thirdly, look for peaks in propagation when there is sunrise or sunset at one end or another of a propagation path. For example, look for a peak in 26 MHz propagation towards the East for the hour or so after your sunrise, and toward the West around your sunset.

Careful planning of your operating times, proper choice of listening frequencies, and diligent study of schedules from overseas broadcast stations will pay rich dividends in entries in your log book. We hope that this section will have helped you understand the fascinating world of shortwave radio propagation better.

BLOCK DIAGRAM

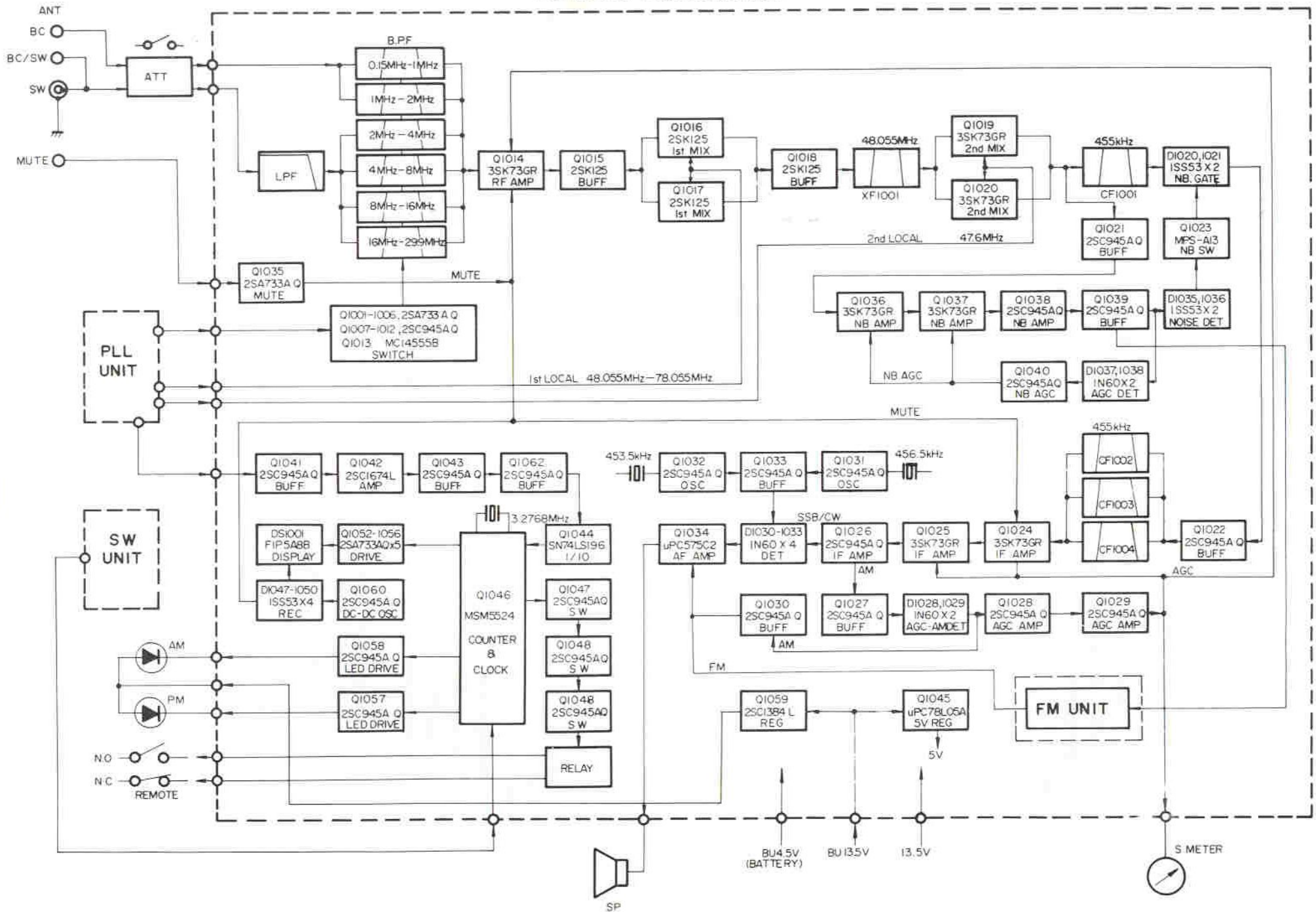

CIRCUIT DESCRIPTION

Reference to the block diagram and the following circuit description will provide you with a better understanding of the design of this receiver. The FRG-7700 is a superheterodyne receiver using up-conversion to a first IF (Intermediate Frequency) of 48 MHz. Synthesized local oscillators are used for both the first and second mixers, providing a high degree of frequency stability.

RECEIVER SIGNAL FLOW

The RF (Radio Frequency) signal from the antenna is fed through the defeatable RF attenuator to the MAIN Unit. The signal is passed through a low-pass filter ($f_c = 30$ MHz), consisting of L_{1001} , C_{1001} , C_{1002} , and then through bandpass filters for the following ranges: 150 kHz – 1 MHz, 1 – 2 MHz, 2 – 4 MHz, 4 – 8 MHz, 8 – 16 MHz, and 16 – 30 MHz. Selection of the filter to be used is provided by diode switches $D_{1001} - D_{1012}$ (1SS53), which are driven by Q_{1013} (MC14555), $Q_{1001} - Q_{1006}$ (2SA733), and $Q_{1007} - Q_{1012}$ (2SA945A-Q), according to the setting of the band switch.

The signal is then amplified by RF amplifier Q_{1014} (3SK73GR), a dual-gate MOS FET with superior linearity and low noise figure. The amplified signal is then fed through buffer Q_{1015} (2SK125) to the first mixer Q_{1016} , Q_{1017} (2SK125) where the RF signal is mixed with the first local oscillator signal (48.055 – 78.055 MHz) delivered from the PLL Unit, resulting in a 48.055 MHz first IF. This up-conversion technique provides superior image rejection characteristics when compared with conventional designs.

The first IF signal is amplified by Q_{1018} (2SK125) and fed through crystal filter XF_{1001} , which has a 20 kHz bandwidth at –6 dB, providing protection from in-band intermodulation distortion while allowing sufficient bandwidth for effective noise blanking. The signal is then delivered to the second mixer Q_{1019} , Q_{1020} (3SK73GR) where the 48.055 MHz first IF signal is mixed with a 47.6 MHz local oscillator signal from the PLL Unit, producing a 455 kHz second IF signal.

The 455 kHz signal is passed through a ceramic filter, CF_{1001} (20 kHz/–6 dB) and noise blanker gate diodes D_{1020}/D_{1021} (1SS53) to the main IF filters: CF_{1002} (SSB/AM-N), CF_{1003} (AM-M), and

CF_{1004} (AM-W), with filter selection made via the mode switch. The filtered IF signal is then delivered to the main IF amplifier chain, consisting of Q_{1024} , Q_{1025} (3SK73GR), and Q_{1026} (2SC945A-Q).

In the SSB and CW modes, the IF signal is coupled to the product detector, a diode ring demodulator consisting of $D_{1030} - D_{1033}$ (1N60), which converts the IF signal into audio using the carrier signal delivered from Q_{1033} (2SC945A-Q). The audio signal is fed to the audio amplifier, Q_{1034} (μ PC575C2), which delivers 1.5 watts of audio power to the speaker.

In the AM mode, the IF signal is coupled from Q_{1026} via C_{125} to buffer amplifier Q_{1027} (2SC945A-Q). The signal is then detected at D_{1028}/D_{1029} (1N60), and the resulting audio signal is fed to the audio amplifier via buffer amplifier Q_{1030} (2SC945A-Q).

NOISE BLANKER CIRCUIT

A portion of the output from the second mixer is fed through buffer Q_{1021} (2SC945A-Q) to amplifiers Q_{1036} , Q_{1037} (3SK73GR) and Q_{1038} , Q_{1039} (2SC945A-Q). When a carrier or noise-free modulated signal is received, the IF signal is rectified by D_{1037} and D_{1038} (1N60), producing a DC voltage. The DC voltage is amplified by Q_{1040} (2SC945A-Q) and fed to gate 2 of Q_{1036} and Q_{1037} , controlling the gain of those stages.

When pulse noise is received, D_{1035} and D_{1036} (1SS53) rectify the IF signal, producing a DC voltage which controls the noise blanker switching diodes (D_{1020}/D_{1021}). Noise pulses have a very short duration, but extremely high amplitude. Because of the very slow time constant of the AGC circuit feeding back to Q_{1036} and Q_{1037} , these short duration pulses will not induce AGC action, and those stages will operate at full gain. When a pulse is received, however, Q_{1023} biases D_{1020} and D_{1021} to block the signal path momentarily.

When a noise pulse and a desired signal are received simultaneously, the blanking action is not impaired, because the relative amplitude difference between the desired signal and the noise pulse is high.

AGC CIRCUIT

A portion of the output from the AM detector is fed to DC amplifiers Q_{1028} and Q_{1029} (2SC945A-Q). This amplified DC voltage is applied to gate 2 of the RF and IF amplifiers, controlling the gain of those stages.

MUTE CIRCUIT

Q_{1035} is normally in the "ON" state, providing normal bias voltage to gate 1 of Q_{1014} and Q_{1024} . When the MUTE terminal is shorted to ground, Q_{1035} turns off, removing the bias voltage from the above transistors, thus silencing the receiver.

CLOCK AND DIGITAL DISPLAY CIRCUIT

A Large Scale Integration (LSI) chip, Q_{1046} (MSM5524), controls both the display of the operating frequency and the time. An 0.455 – 30.455 MHz signal from the PLL Unit is amplified by Q_{1041} (2SC945A-Q), Q_{1042} (2SC1674L), Q_{1043} (2SC945A-Q), then fed through divider (1/10) Q_{1044} (SN74LS196) to the LSI chip. The output from Q_{1046} is fed to the fluorescent display tube, (DS1001), through segment drivers Q_{1052} – Q_{1056} (2SA733A-Q). Q_{1060} and Q_{1061} (2SC945A-Q) act as a DC-DC converter, providing –25 volts DC for the display tube.

The timer control output from the LSI activates relay RL_{1001} , which controls the receiver main power supply ON/OFF function. RL_{1001} also is connected to the REMOTE terminals on the rear panel of the receiver, for control of peripheral station equipment.

PLL CIRCUIT

The first and second local signals (48.055 – 78.055 MHz and 47.6 MHz, respectively) are generated by the dual-loop PLL (Phase Locked Loop) circuit.

A 44.055 – 45.055 MHz signal is generated by VCO (Voltage Controlled Oscillator) Q_{2028} (2SC945A-Q) in PLL Loop 1. This signal fed through buffer Q_{2029} (2SC945A-Q) to mixer Q_{2030} (SN16913P), where the VCO signal is mixed with a 47.6 MHz signal generated by crystal

oscillator Q_{2016} (2SC535A), producing a 3.545 – 2.545 MHz signal which is fed to phase detector Q_{2025} (MC4044P). The phase detector compares the phase of the input signal with that of the VFO signal delivered via Q_{1023} , Q_{2024} (2SC945A-Q); any phase difference is converted to a DC control voltage, which is fed to varactor diodes in the VCO circuit, in order to correct the phase difference and lock the input signal with the VFO signal.

In PLL Loop 2, there are four VCO circuits Q_{2008} – Q_{2011} (2SC945A-Q) which are selected by the band-switch, with the net result being an output signal of 48.055 – 78.055 MHz. This signal is fed to mixer Q_{2033} (SN16913P), where the input signal is mixed with the 44.055 – 45.055 MHz signal delivered from PLL Loop 1, producing a 4 – 33 MHz signal. This signal is fed through divider (1/10) Q_{2036} (HD10551P) to phase detector Q_{2042} (MB8718), which also contains a programmable divider.

Phase detector Q_{2042} compares the phase of the signal from the onboard programmable divider and that of the 100 kHz reference signal generated by Q_{2039} , Q_{2040} (2SC945A-Q), and Q_{2041} (MB84040), producing an error-correcting DC voltage. The dividing ratio of the programmable divider is selected by the bandswitch. The error-correction voltage is fed to varactor diodes in VCO/1 – VCO/4, thus locking a highly stable 48.055 – 78.055 MHz signal, which will be used as the first local signal. The VCO output is fed through buffers Q_{2012} (2SC1047C) and Q_{2013} (2SC1959Y) prior to delivery to the first mixer.

The second local signal (47.6 MHz) is generated by Q_{2016} , then amplified by Q_{2017} (2SC1393L) and fed through buffer Q_{2021} (2SC945A-Q) prior to delivery to the second mixer.

A portion of the first local signal is fed to mixer Q_{2019} (SN16913P), where the signal is mixed with the 47.6 MHz second local signal, producing a signal at 0.455 – 30.455 MHz which is fed to the LSI chip in the counter for display of the operating frequency.

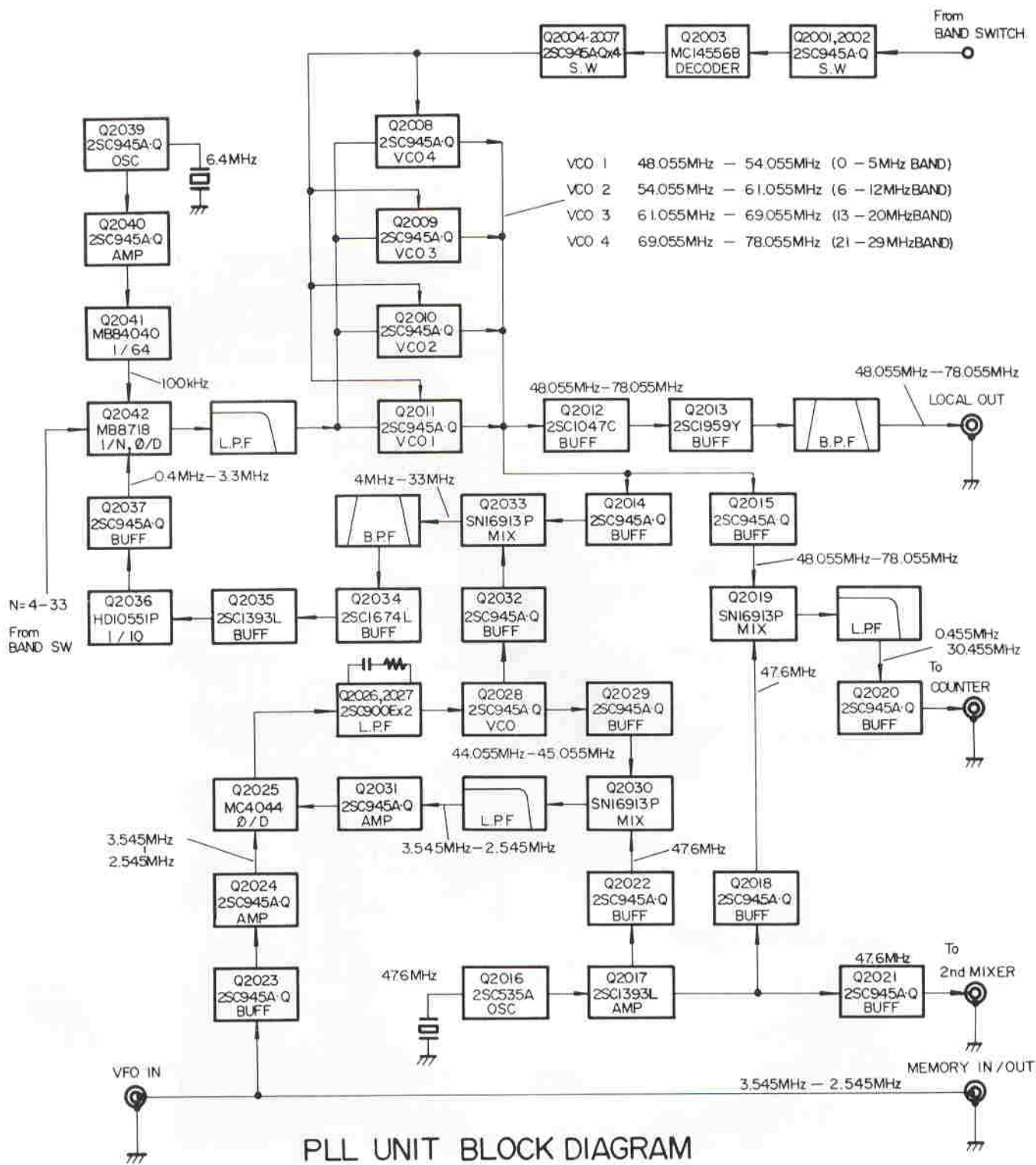

PLL UNIT BLOCK DIAGRAM

MAINTENANCE AND ALIGNMENT

GENERAL

The FRG-7700 has been carefully aligned and tested at the factory prior to shipment. With normal usage, it should not require other than the usual attention given to electronic equipment. Service or replacement of a major component may entail substantial realignment; under no circumstances, however, should realignment be attempted unless the operation of the receiver is fully understood, and the malfunction has been definitely traced to misalignment rather than component failure. Service work should be performed only by experienced personnel using the proper test equipment.

MAIN UNIT

(1) Counter Clock Frequency Adjustment

Connect a frequency counter to TP₁₀₀₇. Adjust TC₁₀₀₃ for a reading of 3.2768 MHz on the counter.

(2) SSB Carrier Frequency Adjustment

- a. Connect a frequency counter to TP₁₀₀₅, and set the MODE switch to the USB position. Adjust TC₁₀₀₂ for a reading of 456.5 kHz on the counter.
- b. Set the MODE switch to the LSB/CW position. Adjust TC₁₀₀₁ for a reading of 453.5 kHz on the counter.

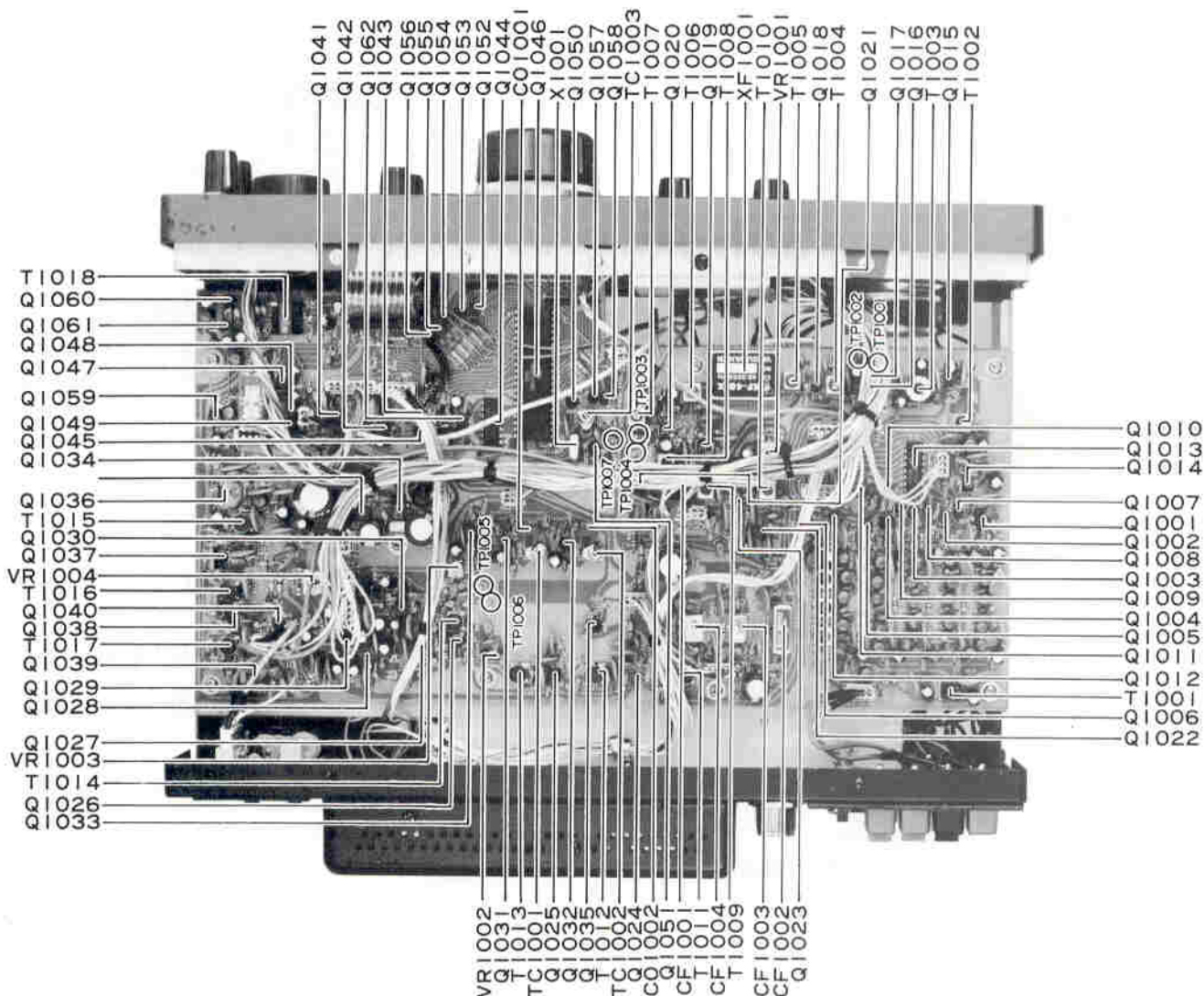

TOP VIEW

(3) First and Second IF Adjustment

Set the MODE switch to LSB/CW, the ATT switch to DX, and rotate the ATT control fully counter-clockwise. Connect a signal generator to the antenna jack, J₁, and set its frequency to 8.01 MHz. Tune the receiver to 8.01 MHz, set the signal generator output to a level sufficient to obtain deflection of the S-meter, and adjust T₁₀₀₄ - T₁₀₀₈ and T₁₀₁₁ - T₁₀₁₄ for maximum S-meter reading.

(4) S-Meter Sensitivity and Full Scale Adjustment

- a. Preset the controls, switches, and dial frequency as in step 3. Set the signal generator output level to 8 dB (ref: 0 dB = 1μV). Adjust VR₁₀₀₂ so that the S-meter just begins to move off the left-hand peg on its scale.
- b. Set the signal generator output level to 90 dB.

Adjust VR₁₀₀₄ for a full scale reading on the S-meter.

(5) NB Adjustment

- a. Connect a VTVM to the source of Q₁₀₃₇, and a signal generator to antenna jack J₁. Set the signal generator output level to 20 dB, output frequency to 8.01 MHz, and adjust T₁₀₁₅ - T₁₀₁₇ for a minimum reading on the VTVM.
- b. Connect a noise generator to antenna jack J₁, and press the NB switch. Adjust VR₁₀₀₁ for a minimum noise level from the speaker.

(6) Trap Adjustment

Connect a signal generator to antenna jack J₁, and set its frequency to the first IF frequency, 48.055 MHz. Set the signal generator output level to a level sufficient to obtain deflection on the S-meter, then T₁₀₀₂ for a minimum reading on the S-meter.

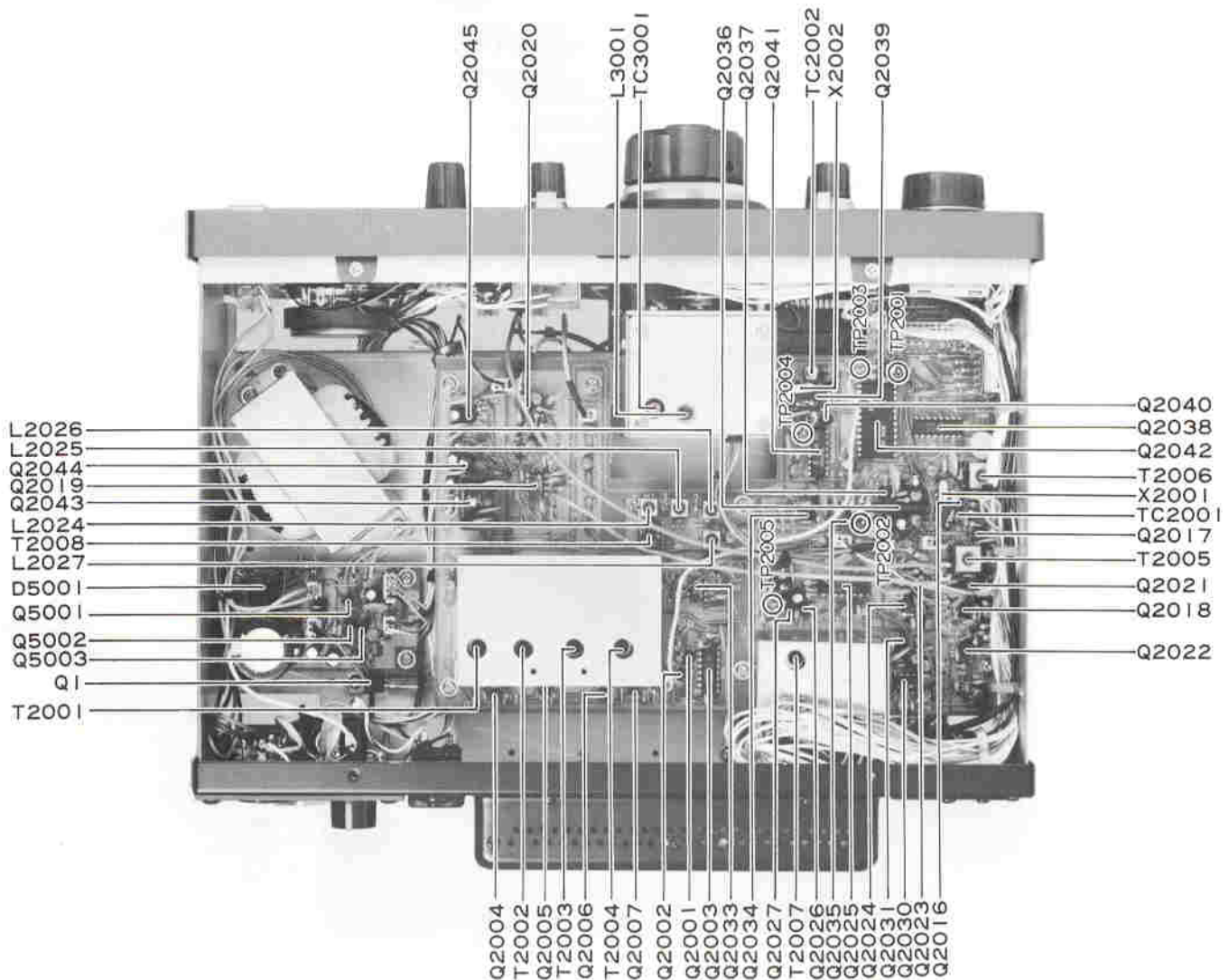

BOTTOM VIEW

PLL UNIT

(1) PLL Reference Oscillator Adjustment

Set the MR switch to off, and connect a frequency counter to pin 9 of Q₂₀₄₁. Adjust TC₂₀₀₂ for a reading of exactly 3.2 MHz on the counter.

(2) PLL Local Alignment

- a. Connect the RF probe of a VTVM to pin 1 of J₂₀₀₅. Adjust T₂₀₀₅ and T₂₀₀₆ for a maximum meter reading on the VTVM (typical value: 100-200 mV RMS).
- b. Connect a frequency counter to pin 1 of J₂₀₀₅. Adjust TC₂₀₀₁ for a reading of exactly 47.6 MHz on the counter.

(3) VCV Line Adjustment

- a. Connect the DC probe of a VTVM to TP₂₀₀₅ (PLL Unit), and rotate the main dial to the "1000" position on the analog dial. Adjust T₂₀₀₇ to secure a reading of 7 volts on the VTVM.
- b. Rotate the main dial to the "0" position on the analog dial. Make certain that the voltage is within the range of 1.5 – 2.0 volts.
- c. Connect the VTVM DC probe to TP₂₀₀₃, and rotate the main dial to the "1000" position.

Set the BAND switch to the 5 MHz band, and adjust T₂₀₀₄ to obtain a reading of 7.4 volts on the VTVM.

- d. Change the BAND switch to the 12, 20, and 29 MHz band positions, and adjust VCO coils T₂₀₀₃, T₂₀₀₂, T₂₀₀₁, respectively, to obtain readings of 7.4 volts on the VTVM.
- e. Set the BAND switch to the 21, 13 and 0 MHz band positions, and rotate the main dial to the "0" position on the analog dial. Make certain that the voltages at TP₂₀₀₃ are within the range of 1.5 – 2.0 volts.

MEMORY UNIT

(1) M FINE Adjustment

Set the M FINE control to the 12 o'clock position, and connect a frequency counter to pin 9 of Q₆₀₂₁. Adjust T₆₀₀₃ for a reading of 8.192 MHz on the counter.

(2) VCV Line Adjustment

Initially set the MR switch in the OFF position, and connect a VTVM to TP₆₀₀₁. Rotate the main dial to the "0" position on the analog skirt, and push the M button. Then press the MR button, and adjust T₆₀₀₁ to obtain a reading of 6.6 volts on the VTVM.

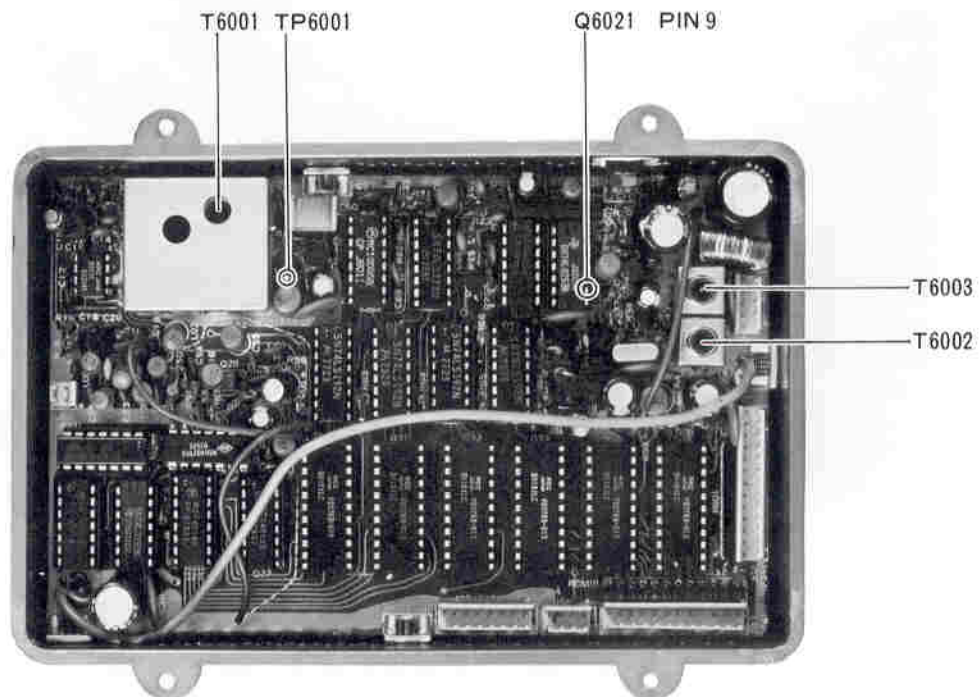

MEMORY UNIT

PARTS LIST

MAIN CHASSIS						PLUG	
Symbol No.	Part No.	Description			P1090187		
	F0002174	Printed Circuit Board		P3,4,9-11,18,19, 21,26,32,33,35, 37,38,40		PI051-02F	
		TRANSISTOR		P2,14,22,39	P1090188	PI051-03F	
Q1	G3402880K	2SD288K		P1,5,6,12,20,25	P1090153	PI051-04F	
				P7,8,13,15,16	P1090154	PI051-05F	
		DIODE		P17,24	P1090156	PI051-07F	
D1	G2090147	LED	TLG208	P23,27-29	P1090157	PI051-08F	
D2	G2090151		TLY208	P30,31	P1090161	PI051-12F	
				P34	P1090162	PI051-13F	
		RESISTOR			P2000018	BATTERY SOCKET S1(006P)	
R3	J01245470	Carbon film	1/4W TJ 47Ω		Q9000096	BATTERY CASE C4	
R1	J01245680	" "	" " 68Ω				
R4	J02245102	" "	" SJ 1kΩ				
R5	J02245103	" "	" " 10kΩ				
R2	J02245223	" "	" " 22kΩ				
		POTENTIOMETER					
VR1	J62800049	DM10A638A-10kB-10kA				TRANSISTOR, FET & IC	
VR2	J60800071	VM10A610E-10kC		Q1001-1006,1035, 1052-1056	G3107331Q	TR	2SA733A-Q
VR3	J62800050	DM10A638A-10kBx2		Q1007-1012,1021, 1022,1026-1033, 1038-1041,1043, 1047-1051,1057, 1058,1060-1062	G3309451Q	"	2SC945A-Q
		CAPACITOR					
C1,2	K12329002	ECKDAL472PE 150VAC 0.0047μF		Q1059	G3313840R	"	2SC1384R
C3,4	K13170473	DB207YF473Z5L5 50WV 0.047μF		Q1042	G3316740L	"	2SC1674L
C5	K40170105	50RL	" 1μF	Q1023	G3090005	"	MPS-A13
C6	K40140475	25RL4R7	25WV 4.7μF	Q1015-1018	G3801250	FET	2SK125
		POWER TRANSFORMER		Q1014,1019,1020, 1024,1025,1036, 1037		"	
PT1	L3030085			Q1034	G1090073	IC	μPC575C2
		METER		Q1045	G1090084	"	μPC78L05A
M1	M0290021	AP-170		Q1044	G1090033	"	SN74LS196
				Q1046	G1090310	"	MSM5524
		SPEAKER		Q1013	G1090309	"	MC14555BCP
SP1	M4090044	SE92BYM-2 8Ω 2W					
		LAMP		D1001-1027,1035, 1036,1041-1044, 1047-1052, 1054-1056	G2090027	Si	1SS53
PL1	Q1000045	12V 150mA K0298-4-0					
		SWITCH					
S1	N4090037	SUF-12	POWER	D1034	G2090001	Si	10D1
S2	N4090038	SUF-24	AGC/NB	D1028-1033, 1037-1040,1057	G2090029	Ge	1N60
S3	N0190076	SRN-2046N	MODE				
S4	N0190074	SRN-1025N	DISP	D1045	G2090156	Zener	RD5.6EB-2
S5	N0190075	SRN-202CN	MEM.CH	D1053	G2090154	Zener	RD7.5EB-1
				D1046	G2090153	Zener	RD10EB-1
		RECEPTACLE					
J1	P1090028	MBR-06D				FLUORESCENT TUBE	
J2	P1090004	SG-7814		DS1001	G6090020	FIP5A8B	
J3	P1090201	UK-0002					
J9	P0090094	PA-125				CRYSTAL	
				X1001	H0102336	HC-18/U	3.2768MHz
		TERMINAL BOARD					
	Q9000089	TERMINAL BOARD ASS'Y				CERAMIC OSCILLATOR	
J5a,b,c	P1090205	UG-0015 #2 (RED)		CO1001	H7900090	CSB453.5A2	453.5kHz
J5d	P1090211	UG-0015 #1 (Black)		CO1002	H7900100	CSB456.5A2	456.5kHz
J7	P1090201	UK-0002					
J8	P1090206	UC-0007-02				CRYSTAL FILTER	
S6	N6090020	OS-22-09S		XF1001	H1102023	XF-48JX	48.055MHz
S7	N0190077	JR-1002-06				CERAMIC FILTER	
FH1	P2000019	FH-032-C		CF1001	H3900230	CFU455C2	

CF1002	H3900041	CFM-455J1	R1219,1229,1254	J02245562	Carbon film	1/4W SJ	5.6kΩ
CF1003	H3900240	CFG455H	R1232,1242,1243	J01245562	" "	" TJ	5.6kΩ
CF1004	H3900220	LF-H12	R1090,1126,1141, 1169,1198	J02245682	" "	" SJ	6.8kΩ
		RESISTOR					
R1213	J10276339	Carbon composition	R1051	J02245822	" "	" "	8.2kΩ
		1/2W GK 3.3Ω	R1004,1006,1007, 1009,1011,1012, 1015,1018,1021, 1023,1047,1049, 1056,1067,1100, 1104,1108,1112, 1115,1121,1124, 1127,1128,1131, 1140,1153,1157, 1171,1179,1182, 1190,1203,1209, 1210,1212,1230, 1233,1249,1250	J02245103	" "	" "	10kΩ
R1257	J10276689	" "					
		1/2W GK 6.8Ω					
R1163,1248,1252	J00245100	Carbon film					
		1/4W VJ 10Ω					
R1055,1066,1071, 1116,1125,1145, 1183,1191,1244, 1245	J00245220	" "					
		" " 22Ω					
R1066	J02245220	" "					
		" TJ 22Ω					
R1084	J02245330	" "					
		" SJ 33Ω					
R1063,1114,1123, 1181,1189,1258	J02245470	" "					
		" " 47Ω					
R1057,1162,1176, 1214	J02245560	" "	R1048,1111,1187, 1207	J01245103	" "	" TJ	10kΩ
		" " 56Ω					
R1058,1062	J02245680	" "	R1065,1149	J02245123	" "	" SJ	12kΩ
		" " 68Ω					
R1064	J02245750	" "	R1069,1220	J02245153	" "	" "	15kΩ
		" " 75Ω					
R1024,1059, 1072-1075,1077, 1079,1082,1090, 1093,1094,1113, 1117,1122,1129, 1133,1135,1139, 1150,1155,1159, 1180,1188,1194, 1197,1201,1216, 1218,1223,1224, 1225,1236	J02245101	" "	R1177	J02245183	" "	" "	18kΩ
		" " 100Ω	R1088,1193	J02245223	" "	" "	22kΩ
			R1165,1204,1227	J02245473	" "	" "	47kΩ
			R1118,1160,1184, 1215	J02245683	" "	" "	68kΩ
			R1068,1070,1119, 1120,1134,1138, 1185,1186,1231	J02245104	" "	" "	100kΩ
			R1167,1234	J02245124	" "	" "	120kΩ
R1005,1008,1010, 1013,1014,1016, 1017,1019,1020, 1022,1083,1098, 1102,1106,1132	J01245101	" "	R1166	J02245154	" "	" "	150kΩ
		" TJ 100Ω	R1142,1173,1199	J02245224	" "	" "	220kΩ
			R1208	J01245224	" "	" TJ	220kΩ
			R1080,1091,1152, 1156,1172	J02245334	" "	" SJ	330kΩ
			R1147	J02245394	" "	" "	390kΩ
R1053	J02245151	" "	R1043-1045	J02245564	" "	" "	560kΩ
		" SJ 150Ω					
R1161,1168,1256	J02245221	" "	R1050	J02245225	" "	" "	2.2MΩ
		" " 220Ω					
R1086,1087,1221	J02245331	" "					
		" " 330Ω					
R1130,1195,1247	J02245391	" "					
		" " 390Ω					
R1002,1003,1046, 1060,1061,1076, 1078,1136,1217	J02245471	" "					
		" " 470Ω					
							BLOCK RESISTOR
R1054,1222	J02245561	" "	RB1001	J40900019	RA1/16K8R-100kΩ	100kΩx8	
		" " 560Ω	RB1002	J40900020	RA1/16K5R-100kΩ	100kΩx5	
R1109	J02245681	" "					
		" " 680Ω					
R1246	J02245821	" "					
		" " 820Ω					
R1081,1092,1143, 1200,1206,1235, 1253	J02245102	" "	VR1003	J51740501	EVNB3AA00B52	500Ω	
		" " 1kΩ	VR1002	J50702202	EVLS0A00B23	2kΩ	
			VR1001	J51721502	EVLS3A00B53	5kΩ	
			VR1004	J51721203	EVLS3A00B24	20kΩ	
R1144	J01245102	" "					
		" TJ 1kΩ					
R1137	J02245122	" "					
		" SJ 1.2kΩ					
R1095	J02245152	" "					
		" " 1.5kΩ					
R1089,1148,1151, 1154,1158,1164, 1170,1205	J02245222	" "					
		" " 2.2kΩ					
R1237-1241	J01245222	" "					
		" TJ 2.2kΩ					
R1025,1028,1031, 1034,1037,1040, 1226,1251,1255	J02245332	" "					
		" SJ 3.3kΩ					
R1001,1085,1099, 1103,1107,1110, 1202,1228	J02245472	" "					
		" " 4.7kΩ					
R1146	J01245472	" "					
		" TJ 4.7kΩ					
R1052	J01245512	" "					
		" " 5.1kΩ					
R1026,1027,1029, 1030,1032,1033, 1035,1036,1038, 1039,1041,1042, 1097,1101,1105, 1175,1192,1196	J02245562	" "					
		" SJ 5.6kΩ					
							CAPACITOR
			C1213	K00172010	DD104SL010C50V02	50WV SL 1pF	
			C1067	K00172030	DD104SL030C50V02	" " 3pF	
			C1068	K00173070	DD104SL070D50V02	" " 7pF	
			C1010,1012	K00175120	DD104SL120J50V02	" " 12pF	
			C1017,1021	K00175180	DD104SL180J50V02	" " 18pF	
			C1079	K00175220	DD104SL220J50V02	" " 22pF	
			C1011,1018,1020	K00175270	DD104SL270J50V02	" " 27pF	
			C1026,1030,1147, 1151	K00175330	DD104SL330J50V02	" " 33pF	

		CONNECTOR		R2048,2050,2053,2055,2061,2063,2067,2070,2072,2075,2076,2080,2081,2088,2098,2102,2107,2108,2114,2115,2120,2130,2135,2140,2145-2147	J02245101	Carbon film 1/4W SJ 100Ω
J1003,1006,1007,1013,1014,1018	P0090120	PI051-02M				
J1002,1010,1015,1020	P0090121	PI051-03M				
J1001,1004,1008	P0090132	PI051-04M				
J1005,1009,1011	P0090133	PI051-05M				
J1012,1017	P0090135	PI051-07M		R2077	J02245151	" " " " 150Ω
J1016	P0090136	PI051-08M		R2117	J02245181	" " " " 180Ω
J1019	P1090196	FJ-10-001		R2062, 2124	J02245221	" " " " 220Ω
				R2089,2142,2144	J02245331	" " " " 330Ω
	Q5000011	Wrapping Terminal C		R2041,2049,2054,2066,2071,2082,2095,2109,2116	J02245391	" " " " 390Ω
				R2013,2020,2027,2034,2104,2136	J02245471	" " " " 470Ω
				R2094,2122	J02245561	" " " " 560Ω
PLL UNIT				R2015,2022,2029,2036,2037,2039,2058,2110,2119,2126,2131,2132	J02245102	" " " " 1kΩ
Symbol No.	Part No.	Description				
PB-2170A	F0002170A	Printed Circuit Board				
	C0021700	P.C.B with Components				
				R2091,2137	J02245152	" " " " 1.5kΩ
		TRANSISTOR, IC		R2005-2008,2038,2073,2096,2118,2125,2134	J02245222	" " " " 2.2kΩ
Q2004-2007	G3107331Q	TR	2SA733A-Q			
Q2016	G3305351	"	2SC535A			
Q2026,2027	G3309000E	"	2SC900E	R2138,2148,2149	J02245272	" " " " 2.7kΩ
Q2001,2002,2008-2011,2014,2015,2018,2020-2024,2028,2029,2031,2032,2037,2039,2040	G3309451Q	"	2SC945A-Q	R2057,2060,2092,2093,2097	J02245472	" " " " 4.7kΩ
Q2012	G3310473	"	2SC1047C	R2011,2018,2025,2032,2046,2069,2079,2103,2105,2112,2129	J02245103	" " " " 10kΩ
Q2044,2045	G3313840R	"	2SC1384R	R2012,2019,2026,2033,2047,2056,2059,2068,2078,2101,2106,2113,2128	J02245223	" " " " 22kΩ
Q2017,2035	G3313930L	"	2SC1393L			
Q2034	G3316740L	"	2SC1674L			
Q2013	G3319590Y	"	2SC1959Y			
Q2043	G3408820Q	"	2SD882Q	R2002,2004,2086,2087	J02245473	" " " " 47kΩ
Q2042	G1090153	IC	MB8718			
Q2041	G1090311	"	MB84040B	R2074	J02245683	" " " " 68kΩ
Q2036	G1090296	"	HD10551	R2001,2003,2009,2010,2016,2017,2023,2024,2030,2031,2051,2065,2090,2099,2100,2111,2133	J02245104	" " " " 100kΩ
Q2025	G1090087	"	MC4044P			
Q2038	G1090312	"	MC14504BCP			
Q2003	G1090128	"	MC14556BCP			
Q2019,2030,2033	G1090012	"	SN16913P			
				R2127	J02245154	" " " " 150kΩ
		DIODE				BLOCK RESISTOR
D2001-2020	G2090027	Si	1SS53			
D2021-2025	G2090043	Varactor	MV-104	RB2001	J40900017	RA1/16-6R1MΩ 1/16W 1MΩx6
D2027,2028	G2090156	Zener	RD5.6EB2			
D2026	G2090155	Zener	RD9.1EB2			
						CAPACITOR
				C2048,2062	K00179001	DD104SL0R5C50V02 50WV SL 0.5pF
		CRYSTAL				
X2001	H0102337	HC-18/U	47.6MHz	C2085,2111,2127	K00172010	DD104SL010C50V02 " " 1pF
X2002	H0102338	"	6.4MHz			
				C2148	K00172020	DD104SL020C50V02 " " 2pF
		RESISTOR				
R2139	J10276479	Carbon composition 1/2W TJ 4.7Ω		C2034,2045	K00172030	D104SL030C50V02 " " 3pF
R2123,2141,2143	J02245100	Carbon film 1/4W SJ 10Ω		C2070,2073,2081,2112,2139	K00172050	DD104SL050C50V02 " " 5pF
R2083-2085	J02245150	"	" " " " 15Ω			
R2040,2043	J02245330	"	" " " " 33Ω	C2010,2017,2168	K06172050	DD104UJ050C50V02 " UJ 5pF
R2044	J02245560	"	" " " " 56Ω			
R2121	J02245820	"	" " " " 82Ω	C2049,2086	K00173060	DD104SL060D50V02 " SL 6pF
R2014,2021,2028,2035,2042,2045	J02245101	"	" " " " 100Ω			

C2108	K06173060	DD104UJ060D50V02 50WV UJ 6pF	C2163,2166,2167, 2173,2177,2178, 2182,2184,2186, 2188-2192	K13170473	DB207YF473Z5L5 50WV 0.047μF	
C2142	K00173080	DD104SL080D50V02 " SL 8pF				
C2043,2044,2063, 2071,2072	K00173100	DD104SL100D50V02 " SL 10pF	C2101,2102,2183, 2185,2187	K40170105	50RL1	" 1μF
C2008,2015,2022, 2028,2105,2106	K06173100	DD104UJ100D50V02 " UJ 10pF	C2180	K40140475	25RL4R7	25WV 4.7μF
			C2103,2110,2159, 2162,2179	K40129004	16RE10	16WV 10μF
C2146	K00175120	DD104SL120J50V02 " SL 12pF	C2012,2019,2025, 2031	K40109002	10RE47	10WV 47μF
C2033,2128,2141	K00175150	DD104SL150J50V02 " " 15pF				
C2144	K00175180	DD104SL180J50V02 " " 18pF	TC2001,2002	K91000029	TRIMMER CAPACITOR	
					ECV1ZW20x53	20pF
C2040,2042,2055, 2058,2082,2149, 2175	K00175220	DD104SL220J50V02 " " 22pF	INDUCTOR			
			L2002,2003,2005	L1190113	FL-3H R22M	0.22μH
C2169	K02179009	DD104CH220J50V02 " CH 22pF	L2001,2004	L1190011	FL-4H R47M	0.47μH
			L2037	L1190013	FL-4H R68M	0.68μH
C2054	K06175220	DD104UJ220J50V02 " UJ 22pF	L2010-2012	L1190009	FL-4H 3R3M	3.3μH
			L2031	L1190014	FL-5H 100K	10μH
C2039,2041,2145	K00175270	DD104SL270J50V02 " SL 27pF	L2028,2029	L1190025	FL-5H 330K	33μH
			L2021,2022	L1190027	FL-5H 390K	39μH
C2143	K00179007	DD104SL300J50V02 " " 30pF	L2006,2007,2015	L1190029	FL-5H 470K	47μH
			L2008,2009,2014, 2016,2020,2023, 2030,2033,2035	L1190020	FL-5H 151K	150μH
C2147	K00179008	DD104SL360J50V02 " SL 36pF	L2013,2017-2019, 2032,2034,2036	L1190017	FL-5H 102K	1mH
C2077,2078	K02179014	DD106CH360J50V02 " CH 36pF	L2024,2026	L0020882		L.P.F
			L2025	L0020871		L.P.F
	K06175390	DD104UJ390J50V02 " UJ 39pF	L2027	L0020873		L.P.F
			TRANSFORMER			
C2007,2014,2021, 2027	K06175470	DD104UJ470J50V02 " " 47pF	T2001	L0020869		
C2119,2121	K00179510	DD104SL510J50V02 " SL 51pF	T2002	L0020868		
			T2003	L0020867		
C2120	K00175101	DD105SL101J50V02 " " 100pF	T2004	L0020866		
			T2005	L0020110	R12-4797	
C2170,2171	K02175151	DD109CH151J50V02 " CH 150pF	T2006	L0020127	R12-4094A	
			T2007	L0020862		
C2133	K30176271	Z17D271K05 " 270pF	T2008	L0020209		
C2150	K10176391	DD104YB391K50V02 " 390pF	SWITCH			
			S2001	N0190072	CB-1-2-40	
C2061,2156	K12171102	DD105E102P50V02 " 0.001μF	CONNECTOR			
			J2004-2006,2008, 2009	P0090120	PI051-02M	
C2001,2011,2013, 2018,2020,2024, 2026,2030,2032, 2035-2038,2046, 2047,2050-2053, 2056,2059, 2064-2069, 2074-2076,2080, 2083,2084, 2081-2091, 2093-2096,2098, 2100,2109, 2113-2118,2124, 2125,2129,2131, 2132,2134, 2136-2138,2140, 2152,2153,2155, 2158,2160,2164, 2165,2172,2174, 2176,2181,2193	K13170103	DB201YF103Z5L5 " 0.01μF	J2007	P0090121	PI051-03M	
			J2010	P0090132	PI051-04M	
			J2001	P0090133	PI051-05M	
			J2002	P0090136	PI051-08M	
			J2003	P0090140	PI051-12M	
				Q5000011	Wrapping terminal C	
C2002-2006,2057, 2060,2079,2092, 2097,2099,2104, 2126,2130,2135, 2154,2157,2161	K13170473	DB207YF473Z5L5 0.047μF				

FM UNIT			INDUCTOR		
Symbol No.	Part No.	Description	L7001,7002	L1190017	FL5H 102K 1mH
PB-2176	F0002176	Printed Circuit Board			
	C0021760	P.C.B with Components			
			J7001	P0090167	PI011-08M 8P
		TRANSISTOR & IC			
Q7001,7003-7007	G3309451Q	TR 2SC945A-Q			
Q7002	G1090059	IC TA-7061AP			
		DIODE			
D7001-7004	G2001880F	Ge 1S188FM	VFO UNIT		
D7005	G2090027	Si 1SS53	Symbol No.	Part No.	Description
			PB-2172	F0002172	Printed Circuit Board
		THERMISTOR		C0021720	P.C.B with Components
TH7001	G9090001	SDT-250			TRANSISTOR
			Q3001-3003	G3309451Q	2SC945A-Q
		CERAMIC FILTER			
CF7001	H3900030	LFB-15			RESISTOR
			R3015	J02245330	Carbon film 1/4W SJ 33Ω
		CERAMIC DISCRIMINATOR	R3007,3010-3012,3016	J02245101	" " " " 100Ω
CD7001	H7900010	455D	R3004,3008,3009,3014	J02245102	" " " " 1kΩ
		RESISTOR			
R7022	J02245470	Carbon film 1/4W SJ 47Ω	R3003	J02245222	" " " " 2.2kΩ
R7003,7005,7007,7012,7029,7030	J02245101	" " " " 100Ω	R3001	J02245183	" " " " 18kΩ
R7017	J02245221	" " " " 220Ω	R3005	J02245223	" " " " 22kΩ
R7001	J02245102	" " " " 1kΩ	R3002	J02245333	" " " " 33kΩ
R7019,7023	J02245152	" " " " 1.5kΩ	R3006	J02245104	" " " " 100kΩ
R7004,7006,7008,7011	J02245222	" " " " 2.2kΩ	R3013	J02245154	" " " " 150kΩ
R7028	J02245472	" " " " 4.7kΩ			CAPACITOR
R7013,7015,7018	J02245562	" " " " 5.6kΩ	C3008	K02173100	DD104CH100D50V02 50WV CH10pF
R7026,7027	J02245682	" " " " 6.8kΩ	C3003	K06179009	DD105UJ560J50V02 " " 56pF
R7009,7010,7021,7031,7032	J02245103	" " " " 10kΩ	C3004	K02175101	DD107CH101J50V02 " " 100pF
R7020,7024	J02245823	" " " " 82kΩ	C3002	K02179019	DD107CH910J50V02 " CH 91pF
R7025	J02245104	" " " " 100kΩ	C3007	K30176681	LCQ18681K05 680pF
R7002	J02245224	" " " " 220kΩ	C3013,3014	K10176681	DD104B681K50V02 " 680pF
R7014,7016	J02245564	" " " " 560kΩ	C3006	K30209001	DM19D102K1 100WV 1000pF
		CAPACITOR	C3001	K30209006	DM19D242K1 " 2400pF
C7017	K00179005	DD104SL200J50V02 50WV SL 20pF	C3005,3010,3012	K13170103	DB201YF103Z5L5 50WV .001μF
C7027	K00175101	DD105SL101J50V02 " " 100pF	C3009,3011,3015,3016	K13170473	DB207YF473Z5L5 " 0.047μF
C7010,7016	K12171102	DD105E102P50V02 " 0.001μF			VARIABLE CAPACITOR
C7028	K13170472	DB201YF472Z5L5 " 0.0047μF	VC3001	K90000034	C-613A132
C7001,7003,7004,7009,7014,7015,7019,7026,7029	K13170103	DB201YF103Z5L5 " 0.01μF			TRIMMER CAPACITOR
C7018	K13170223	DD109F223Z50V02 " 0.022μF	TC3001	K91000013	ECV-1ZW20x32 50pF
C7011,7012	K50177223	50F2U223M " 0.022μF			INDUCTOR
C7002,7005-7008,7020	K13170473	DB207YF473Z5L5 " 0.047μF	L3001	L0020062	R12-5775
C7013	K70167224	CS15E1VR22M 35WV 0.22μF	L3003	L1190009	FL4H 3R3M 3.3μH
C7024,7025	K40170105	50RL1 50WV 1μF	L3002	L1190016	FL5H 101K 100μH
C7022,7023	K40140475	25RL4.7 25WV 4.7μF			LAMP
C7021,7030,7031	K40120106	16RL10 16WV 10μF	PL3001	Q1000043A	K0298-4-0 12V, 100mA
					TERMINAL
				Q5000020	MS-60121

SWITCH UNIT			MEMORY UNIT (OPTION)		
Symbol No.	Part No.	Description	Symbol No.	Part No.	Description
PB-2173	F0002173	Printed Circuit Board	PB-2175A	F0002175A	Printed Circuit Board
	C0021730	P.C.B with Components		C0021750	P.C.B with Components
		TRANSISTOR			TRANSISTOR, FET & IC
Q4001,4002	G3309451Q	2SC945A-Q	Q6036	G3107331Q	TR 2SA733A-Q
			Q6017,6018	G3309000E	" 2SC900E
		DIODE	Q6005,6015,6016,6029	G3309451Q	" 2SC945A-Q
D4001,4002	G2090134	LED TLY-205	Q6014	G3313170R	" 2SC1317R
		RESISTOR	Q6003,6006	G3316740L	" 2SC1674L
R4008	J20336100	Metallic film 2W 10Ω	Q6013,6037	G3408820Q	" 2SD882Q
R4004	J01245391	Carbon film 1/4W TJ 390Ω	Q6001,6002	G3801070C	FET 2SK107-3
R4005,4006	J01245681	" " " " 680Ω	Q6028	G4800730G	" 3SK73GR
R4002,4003,4007	J01245102	" " " " 1kΩ	Q6004	G1090313	IC μPB553C
R4001	J01245562	" " " " 5.6kΩ	Q6030-6035	G1090227	" μPD5101LC
			Q6007	G1090296	" HD10551
		SWITCH	Q6008	G1090100	" SN74LS123
S4001-4004	N5090003	KEF-10901	Q6009-6012	G1090019	" SN74LS192
S4005	N4090039	SUT-42A	Q6025	G1090317	" SN74LS290
			Q6021	G1090315	" SN74LS293
	T9203650	FLAT CABLE	Q6020,6022	G1090165	" MC14024BCP
			Q6019	G1090314	" MC14046BCP
			Q6023	G1090126	" MC14069UBCP
			Q6026,6027	G1090108	" MC14518BCP
			Q6024	G1090316	" MSM4023RS
					DIODE
			D6001,6002	G2090073	Varactor FC-52M
			D6007	G2090040	Varactor FC-63
			D6003,6010	G2090156	Zener RD5.6EB2
			D6004	G2090153	Zener RD10EB1
		TRANSISTOR	D6005,6006,6008,6009	G2090027	Si ISS53
Q5001-5003	G3309451Q	2SC945A-Q	D6011,6012	G2090029	Ge 1N60
		DIODE			CRYSTAL
D5001	G2090157	Si S2VB10F	X6001	H0102339	HC-18/U, 3P 16.384MHz
D5002	G2090158	Zener RD4.7EB2			RESISTOR
D5003	G2090159	Si S2V10	R6027	J20306100	Metallic film 1W 10Ω
		RESISTOR	R6029	J02245100	Carbon film 1/4W SJ 10Ω
			R6019	J02245270	" " " " 27Ω
R5005	J02245331	Carbon film 1/4W SJ 330Ω	R6060	J20306330	Metallic film 1W 33Ω
R5003,5004	J02245471	" " " " 470Ω	R6005,6011,6012,6017,6020,6023,6030,6035,6042,6055,6056	J02245100	Carbon film 1/4W SJ 100Ω
R5002	J02245122	" " " " 1.2kΩ			
R5001	J02245182	" " " " 1.8kΩ	R6001,6004,6025,6026,6028	J02245221	" " " " 220Ω
R5007	J02245472	" " " " 4.7kΩ			
R5006	J02245682	" " " " 6.8kΩ	R6013,6024	J02245391	" " " " 390Ω
		CAPACITOR	R6018	J02245471	" " " " 470Ω
C5006	K13170473	DB207YF473Z5L5 50WV 0.047μF	R6067	J02245561	" " " " 560Ω
C5004	K40170105	50RL1 " 1μF	R6036,6038,6058,6062	J02245102	" " " " 1kΩ
C5003,5005	K40120106	16RL10 16WV 10μF	R6041	J02245182	" " " " 1.8kΩ
C5002	K40120336	16RL33 " 33μF	R6014,6043	J02245222	" " " " 2.2kΩ
C5001	K40149013	RPE-25V682M 25WV 6800μF	R6063-6066	J02245272	" " " " 2.7kΩ
			R6068	J10246332	" composition " GK 3.3kΩ
		CONNECTOR	R6040	J02245562	" film " SJ 5.6kΩ
J5001-5003	P0090120	PI051-02M	R6034,6046,6049,6053,6059	J02245103	" " " " 10kΩ
J5004	P0090132	PI051-04M	R6010,6015,6022	J02245183	" " " " 18kΩ
	Q5000011	Wrapping terminal C	R6009,6016,6021,6031,6033,6051	J02245223	" " " " 22kΩ
			R6050	J02245333	" " " " 33kΩ

R6052	J02245393	Carbon film	1/4W SJ	39kΩ			INDUCTOR	
R6002,6003,6006,6007	J02245473	" "	" "	47kΩ	L6006	L1190005	FL4H 1R0M	1μH
R6008,6032,6044	J02245104	" "	" "	100kΩ	L6004,6008	L1190009	FL4H 3R3M	3.3μH
R6037	J02245124	" "	" "	120kΩ	L6005,6007	L1190111	FL4H 5R6K	5.6μH
R6045	J02245154	" "	" "	150kΩ	L6001,6002,6009,6012,6014	L1190020	FL5H 151K	150μH
R6057	J02245184	" "	" "	180kΩ	L6003,6010,6016	L1190017	FL5H 102K	1mH
R6061	J02245224	" "	" "	220kΩ	L6011	L2030067B	S/N COIL	3mH
					L6013,6015	L1190035	FL7H 392J	3.9mH
		BLOCK RESISTOR						
RB6001	J40900018	RA1/16K9R	100kΩ				TRANSFORMER	
		1/16W	100kΩx9		T6001	L0020110		R12-4797A
					T6002	L0020864		VCO COIL
					T6003	L0020865		"
		CAPACITOR						
C6044	K06173060	DD104UJ060D	50V02	50WV UJ 6pF			CONNECTOR	
C6001,6002	K02173070	DD104CH070D	50V02	" CH 7pF	J6006	P0090120	PI051-02M	2P
C6011,6027,6069	K00175120	DD104SL120J	50V02	" SL 12pF	J6004	P0090132	PI051-04M	4P
C6012	K00175270	DD104SL270J	50V02	" " 27pF	J6001	P0090133	PI051-05M	5P
C6043	K06175330	DD104UJ330J	50V02	" UJ 33pF	J6005	P0090136	PI051-08M	8P
C6067	K00175560	D104SL560J	50V02	" SL 56pF	J6003	P0090140	PI051-12M	12P
C6049	K02175560	DD106CH560J	50V02	" CH 56pF	J6002	P0090141	PI051-13M	13P
C6045	K06179009	DD105UJ560J	50V02	" UJ 56pF		Q5000011	Wrapping terminal C	
					ACCESSORIES			
C6046	K02175151	DD109CH151J	50V02	" " 150pF	Symbol No.	Part No.	Description	
C6023,6025	K10176561	DD104B561K	50V02	" 560pF		Q3000004A	Wire Antenna	
C6022,6026	K10176821	DD104B821K	50V02	" 820pF		R3054620	FOOT	H-30
C6003,6004,6006,6007,6008,6010,6013,6014,6030,6031,6068	K12171102	DD105E102P	50V02	" 0.001μF		Q0000002	Fuse 1A	(AC100-120V)
						Q0000001	0.5A	(AC200-240V)
							AC POWER CORD	
C6024	K10179022	2222-660-02272		" 2700μF		T9013280	2 wire, 2 prong plug DC-546-007	
C6009,6016-6021,6029,6033,6034,6038,6042,6047,6048,6054-6059,6061	K14179002	RD204YM0.01μF		" 0.01μF		T9013282	3 wire, 3 prong plug (UL) UC-904-016	
						T9013284	3 wire, 2 prong EU plug EC-407-007	
						T9013283	3 wire, 3 prong Australian plug SC-411-001	
C6053	K50177103	S0F2U103M	"	0.01μF				
C6005,6036,6051,6070-6073	K13170473	DB207YF473Z	5L5	0.047μF		S3000023	Mini Belt C	
C6064	K23170003	RPE112F104Z	50V	0.1μF				
C6050	K54200001	B32561-A1105J		100WV 1μF				
C6015,6032,6035,6039,6060,6066	K40120106	16RL10	16WV	10μF				
C6052,6062	K40120226	16RL22	16WV	22μF				
C6063,2065	K40149003	25RE100	25WV	100μF				
C6041	K40120227	16RL220	16WV	220μF				
C6040	K40129031	16RC470	"	470μF				
C6037	K40089004	6.3RE1000	6.3WV	1000μF				
		MODULE						
RCM6001	Q80000005	RK1/16R-11R	100kΩ/103Z50	(1/16W 100kx11, 50WV 0.01μFx11)				

